



# CATALOG 2017

ELECTRIC WATER HEATER  
and VENTILATION





# CATA WORLDWIDE

## In over 80 countries

Manufacturer for home appliances, **Cata** was founded in Torelló in 1947. It is a leading brand and a pioneer in extraction business.

Its extensive product catalogue includes the most complete and innovative range of Domestic and Professional Extraction.



Based in Torelló, in the province of Barcelona, **Cata** also owns factories in Torelló (Spain), Sao Paulo (Brazil) and Xiao Lan and Shunde (China) and is in constant international expansion thanks to its team of professionals committed to the manufacture and marketing of an extensive range of products.

**Cata** has reached its position as leader in the extraction market thanks to its great capacity to innovate and its ability to anticipate market needs. Over recent years, it has undergone significant growth in both the Spanish and international markets, based on excellent quality and a high degree of competitiveness in all its products.

**Cata's** commitment to quality has been borne out by the highest certification, ISO 9001, awarded by the Bureau Veritas Quality International and accredited by the Dutch Council for Accreditation. These international standards ensure a maximum level of quality in the design and manufacture of all products. Likewise, **Cata** products respond to technical and safety regulations and have been obtained the European approvals of the C. C. A. (Cenelec Certificate Agreement). As a result, **Cata** is currently one of the leading extraction companies in the world.



# ELECTRIC WATER HEATER (EWH)

Reliability & efficiency  
Installation versatility  
High quality components  
Security

## Reliability & Efficiency

By using double resistances circuit, Cata's new EWH offer greater reliability and guarantee proper operation. They incorporate the sheathed thermostat, extending the life of the component. In addition, their best polyurethane insulation foam free of CFC and HCFC of uniform density and perfect adhesion, guarantee minimum heat loss, a much smoother operation, allowing it to be one of the most efficient EWH in the market.

## Installation versatility

All the models that appear in the catalog (except for TS-30 SL) offer two installation possibilities: vertical and horizontal installation. Thanks to the position of heating elements, water heaters can be installed horizontally or vertically, depending on the requirements of each user.

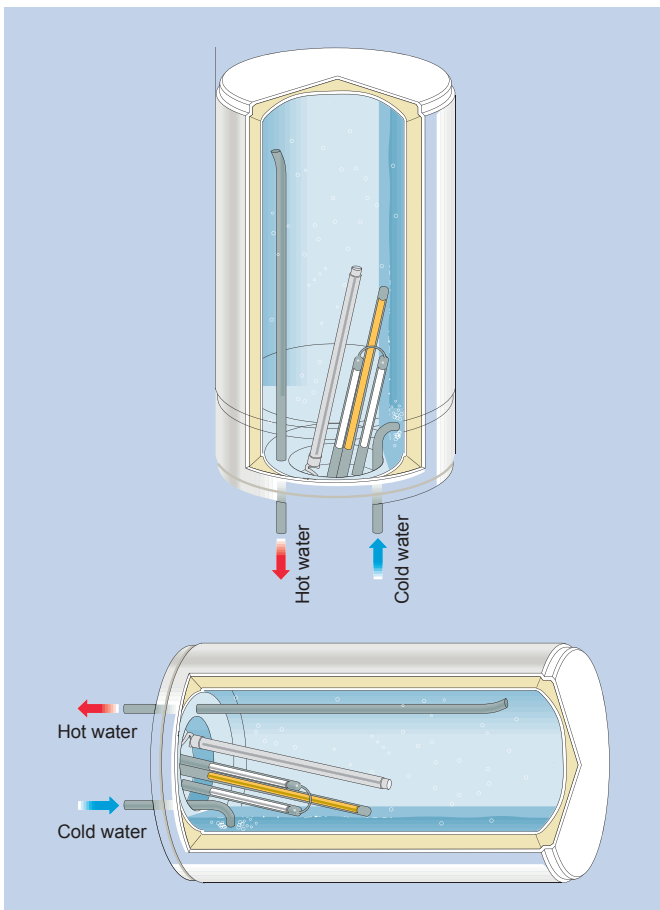

## High quality components

The range of Cata electric water heater incorporate an outer rolled steel covering with epoxy paint protection, which prevents oxidation and gives it an IP24 protection rating. Inside it has high efficiency insulation, ensuring minimum heat loss. All models incorporate magnesium anode, guaranteeing perfect electrochemical protection. They also have sheathed heating elements with double protective enamel and independent functioning, which can be replaced without draining the water tank and allowing the heater to continue operating even if one of the heating elements is not working.

## Security

We offer products with electrical safety: through two thermostats, one for temperature control and another for security, which switches off the water heater in case of failure of the first one; and hydraulic safety, which prevents that the pressure inside the unit exceeds the nominal design pressure.



## European standard for eco-design (Dir. 2009/125/EC) and energy labeling (Dir. 2010/30/EC)

### Why this new legislation?

To help with climate change and to reduce energy consumption and natural resources of the European Community and its member countries. These rules have been developed for eco-design of products (ErP Directive) and regulations for energy labeling (Energy Labelling Directive) thereof in an effort to achieve an improvement of products and the natural resources used in its production and the energy resources used in its operation.

### When?

Both the ErP Directive and Energy Labelling Directive will only be used for products launched on the market beginning on 09.26.2015. Products purchased before or already in the point of sale or stores distributors may continue be sold and installed though not meeting the new requirements.

### Who is affected by these regulations?

We, the manufacturers, that must follow the established policy and begin to develop our products according to the ErP Directive, so as to improve its operating performance, in order to remove less efficient technologies from the market and, so that to be visible for the customer the products have to be labeled according to the Energy Labelling Directive, which also defines the responsibilities of suppliers and sellers.

The installation technician. They should know which products follow the new directives of Eco-Design and inform customers about the reasons of the usage of more efficient appliances. In case of installing mixed heating systems the energy labeling for complete systems must also be elaborated (including boiler, solar support, accumulator, etc.)

### And what about electric heaters?

According to the specific regulations for appliances that produce hot water (Reg. 814/2013), it is necessary to meet efficiency minimum requirements for appliances that can be produced and labeled with EC labeling. They also have to have an energy label and a data sheet as explained in Reg. 811/2013. The initial date to include this information in appliances is September 26, 2015.

### Cata guarantees:

- All our electric water heater obey the directive.
- Detailed technical and normative information for our customers.
- Customer service available for any questions.

### How do I read the energy label on my Cata electric water heater?

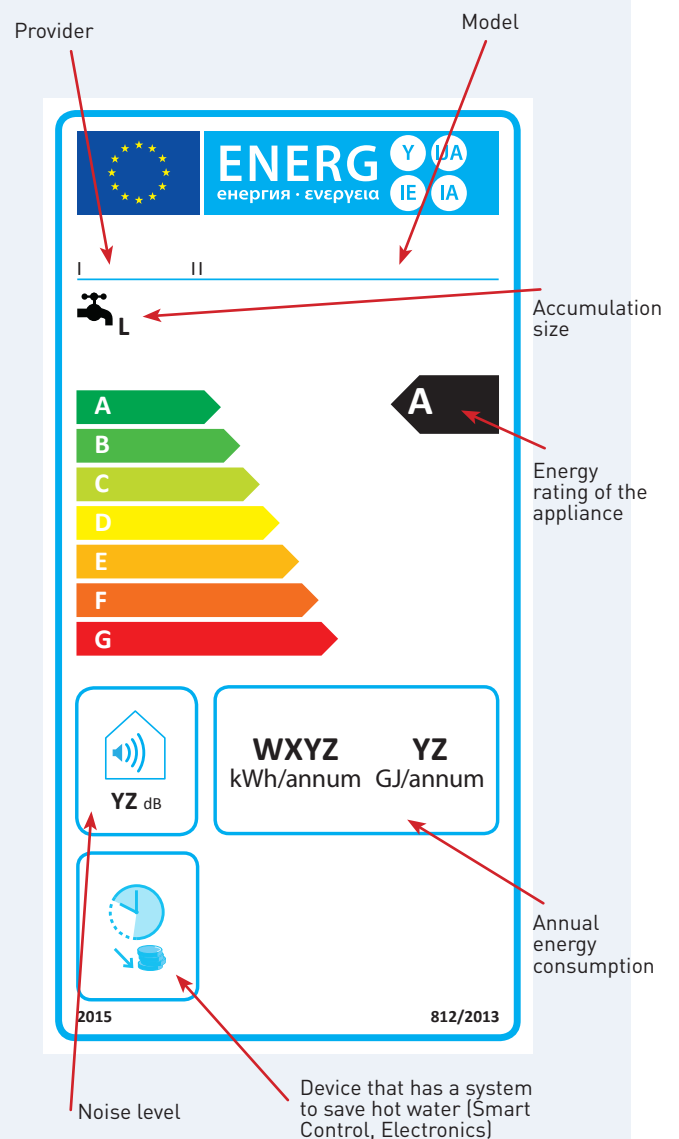

## TS-30 SL

## EWH



- Round outer shape
- Vertical installation
- **Fits into kitchen furniture**
- **Independent sheathed heating elements 2 x 800 watts**
- **Steel tank with vitrified titanium enamel at 850°C**
- **Adjustable thermostat with front control**
- Heating indicator
- Magnesium anode
- **High efficiency insulation 25mm**
- Sheathed thermostatic sensor
- Safety thermostat
- Insulating sleeves
- 10bar safety valve with drain device
- Epoxy paint coated exterior
- 30L capacity
- Energy class: B

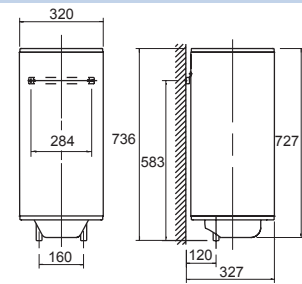

736mm high x 320mm wide x 327mm deep



High efficiency insulation



vertical



sheathed resistors

### TS-30 SL

Code **03100000**

EAN **8422248065351**

## TS-30 / TS-50

## EWH



- Round outer shape
- **Reversible: horizontal and vertical installation**
- **Independent sheathed heating elements 2 x 800 watts**
- **Steel tank with vitrified titanium enamel at 850°C.**
- **Adjustable thermostat with front control**
- Heating indicator
- Magnesium anode
- **High efficiency insulation 25mm - 28mm**
- Sheathed thermostatic sensor
- Safety thermostat
- Insulating sleeves
- 10bar safety valve with drain device
- Epoxy paint coated exterior
- 30L - 50L capacity
- Energy class: B (TS-30) C (TS-50)

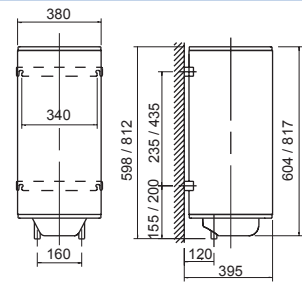

604/817mm high x 380mm wide x 395mm deep



High efficiency insulation



reversible



sheathed resistors

### TS-30

Código **03110000**

EAN **8422248065368**

### TS-50

Código **03111000**

EAN **8422248065375**

## TS-75 / TS-100

## EWH



- Round outer shape
- **Reversible: horizontal and vertical installation**
- **Independent sheathed heating elements 2 x 900 watts**
- **Steel tank with vitrified titanium enamel at 850°C**
- **Adjustable thermostat with front control**
- Heating indicator
- Magnesium anode
- **High efficiency insulation 33mm**
- Sheathed thermostatic sensor
- Safety thermostat
- Insulating sleeves
- 10bar safety valve with drain device
- Epoxy paint coated exterior
- 75L - 100L capacity
- Energy class: C

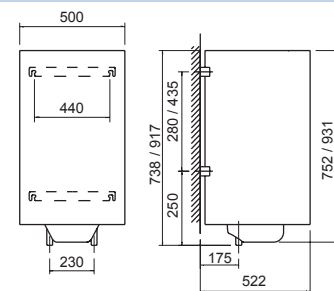

752/931mm high x 500mm wide x 522mm deep



High efficiency insulation



reversible



sheathed resistors

### TS-75

Código **03112000**

EAN **8422248065382**

### TS-100

Código **03113000**

EAN **8422248065399**

TECHNICAL SPECIFICATIONS	ELECTRIC WATER HEATERS				
Models	TS-30 SL	TS-30	TS-50	TS-75	TS-100
Code	03100000	03110000	03110000	03112000	03113000
EAN Code	8422248065351	8422248065368	8422248065375	8422248065382	8422248065399
Sound Power Level inside (dB(A))	15	15	15	15	15
Declared Load Profile	S	S	M	M	L
Energy Efficiency Class	B	B	C	C	C
Energy Efficiency (%)	35	36	36	36	37
Annual Electricity Consumption (kWh)	524517	1413	1408	2748	-
Daily Electricity Consumption (kWh)	2,47	2,43	6,61	6,58	12,77
Temperature adjusted Selector/Thermostat (°C)	60	71	65	62	65
Capacity (l)	30	30	50	75	100
Mixed water at 40°C (l)	41,57	44,24	76,07	103,55	146,58
Installation Position	Vertical	Vertical / Horizontal	Vertical / Horizontal	Vertical / Horizontal	Vertical / Horizontal
Thermostat control location	Front	Front	Front	Front	Front
Temperature Regulation (°C)	20-70	20-70	20-70	20-70	20-70
Heating indicator light	•	•	•	•	•
Magnesium Anode	•	•	•	•	•
Type of heating elements	Independent sheathed	Independent sheathed	Independent sheathed	Independent sheathed	Independent sheathed
Number of Heating elements and power (W)	2x800	2x800	2x800	2x900	2x900
Power Supply (V / Hz)	230/50	230/50	230/50	230/50	230/50
Power (W)	1.600	1.600	1.600	1.800	1.800
Intensity at 230V (A)	7	7	7	7,82	7,82
Heating Time to 65° C (+50°C)	1h 05min	1h 05min	1h 50min	2h 25min	3h 15min
Static losses to 65°C (kWh in 24h)	0,63	0,64	0,77	0,93	1,09
Average thickness of insulation (mm)	25	25	28	33	33
Water Connection (BSP)	1/2"1/2"	1/2"	3/4"	3/4"	-
Highest Pressure (bar)	10	10	10	10	10
Electrical Connection (cable with plug)	•	•	•	•	•
Water fall Vertical protection	•	•	•	•	•
Water projection protection	•	•	•	•	•
Protection rate	IP24	IP24	IP24	IP24	IP24
Net weight (Kg)	14,514,5	19,5	28	33,5	-
<b>Accessories</b>					
Round Fastener	-	-	-	02831001	02831001
EAN code	-	-	-	8422248065566	8422248065566



AXIAL BATHROOM FANS

E GLASS SERIES. Energy-efficient. Low-noise

E - p.10-11

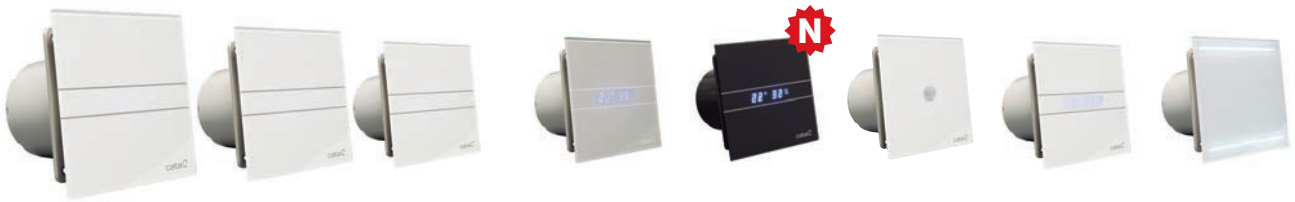

MATIC SERIES

X-MART Matic - p. 12

B-Matic - p. 13



DESIGN SERIES

X-MART - p. 14

SILENTIS - p. 15



CLASIC SERIES

B-Plus - p. 16

B - p. 17

B-Pir - p. 17



CENTRIFUGAL BATHROOM FANS

CB 100 PLUS - p. 18

CB-250 PLUS - p. 18





## IN-LINE DUCT FANS

### Professional Series

Duct in line - p. 19



### Axial

MT - p. 20

Kit in Line - p. 20

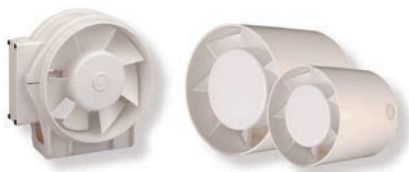

## WALL FANS

LHV - p. 21

B - p. 22

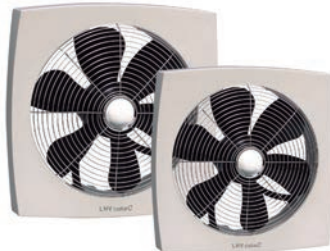

## KITCHEN EXTRACTION

Professional 750 / 500- p. 23

600 PLUS 2V / GS 600 - p. 24

GS 400M / GS 400 P - p. 24



## DOMESTIC VENTILATION ACCESSORIES

Accessories - p. 26-27



FIXED GRILL



GRILL ON PRESSURE



GLASS KIT



RING FIXTURE



BACKDRAUGHT SHUTTER



ANTI RETURN SHUTTER



SUPPORT



SPEED CONTROL



METAL FILTER

## PERFORMANCE CURVES

p. 29 - 33

# AXIAL BATHROOM FANS

## E GLASS Series. Energy-efficient. Low-noise

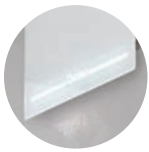

AMBIENT LIGHT



VERY SILENT



HIGHT ENERGY EFFICIENCY



LED 2x2W ADJUSTABLE INTENSITY



LIGHTED DISPLAY



FRONT GLASS



PIR: INFRA RED SENSOR ACTIVATED BY PRESENCE

- **Perimeter extraction** system.
- **Glass cover.**
- Available models with ambient light and infra-red sensor activated by presence (ø100).
- **High-performance plastic housing and impeller.**
- **Temperature and humidity display** (available on humidistat model).
- Backdraught shutter (accessory).
- Fitted with 220-240 50/60Hz motors (110-127V 60Hz on request), IP-44 protection and insulation class B as standard.
- **Minimum sound level of 17dB (according to the model)**
- 2-speed function (humidistat version only), to be selected prior to installation between continuous or NON continuous working.
- 1st speed: slow speed for continuous extraction.
- 2nd speed: activates when light is switched on, by activating the humidistat or the timer.



E-100 GLASS PIR - Infra red sensor, activated by presence

E-100 GLASS LIGHT

## REMOVABLE GLASS FRONT



### EASILY REMOVABLE

Easy and speedy removal of the cover using a single tool (included in the packaging) which is also used to adjust the timer (GT and GTH version) and the humidistat (GTH version).

### EASY TO CLEAN

Extra-flat glass cover that is easy to clean just by running a damp cloth over it.

E-100 G  
E-120 G  
E-150 G  
E-100 GT  
E-120 GT  
E-150 GT



E-100 GS  
E-100 GST

E-100 GSTH



E-100 PIR



E-100 GTH  
E-120 GTH  
E-150 GTH



E-100 GL



E-100 G BK  
E-100 GT BK



E-100 GTH BK

CODE	MODEL	COLOR	EAN CODE	VERSION	Ø (mm)	Speed (r.p.m)	Input Power (W)	Maximum Airflow (m³/h)	Sound Pressure Level dB(A)	Units per box
<b>HYGRO SERIES</b>										
00900200	E-100 GTH	□	8422248049634	●●	100	1ª vel 1100 2ª vel 2600	4 8	36 115	17 31	6
00901200	E-120 GTH	□	8422248056823	●●	120	1ª vel 900 2ª vel 2400	6 11	140 210	19 33	6
00902200	E-150 GTH	□	8422248056854	●●	150	1ª vel 900 2ª vel 2400	10 19	225 350	23 35	6
00900600	E-100 GSTH	■	8422248056076	●●	100	1ª vel 1100 2ª vel 2600	4 8	36 115	17 31	6
<b>N</b> 00900602	E-100 GTH BK	■	8422248071895	●●	100	1ª vel 1100 2ª vel 2600	4 8	36 115	17 31	6
<b>TIMER SERIES</b>										
00900100	E-100 GT	□	8422248049627	●	100	2600	8	115	31	6
00901100	E-120 GT	□	8422248056816	●	120	2400	15	210	33	6
00902100	E-150 GT	□	8422248056847	●	150	2200	21	350	35	6
00900500	E-100 GST	■	8422248056069	●	100	2600	8	115	31	6
<b>N</b> 00900502	E-100 GT BK	■	8422248071888	●	100	2600	8	115	31	6
00900001	E-100 GLT	□	8422248056786	●	100	2600	8+4	115	31	6
<b>STANDAR SERIES</b>										
00900000	E-100 G	□	8422248049610	●	100	2600	8	115	31	6
00900400	E-100 GS	■	8422248056052	●	100	2600	8	115	31	6
<b>N</b> 00900402	E-100 G BK	■	8422248071871	●	100	2600	8	115	31	6
00901000	E-120 G	□	8422248056809	●	120	2400	15	210	33	6
00902000	E-150 G	□	8422248056830	●	150	2200	21	350	35	6
<b>PIR SERIES</b>										
00900300	E-100 SENSOR	□	8422248057622	●	100	2600	8	115	31	6

**DIMENSIONS mm**

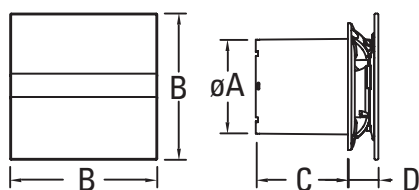

	Ø A	B	C	D
E GLASS -100	98	150	94	28,5
E GLASS -120	118	170	94	35
E GLASS -150	148	190	94	45
E GLASS -100 LIGHT/SENSOR	98	150	94	35

**Versions**



**STANDARD**  
In combination with light, fans switches on.



**TIMER**  
Electronic timer adjustable from 3 to 15 minutes.



**HYGRO**  
Adjustable humidity detector from 40% to 95%, and adjustable electronic timer from 0 to 15 minutes.



**PIR**  
Infra red sensor activated by presence and adjustable electronic timer from 40 seconds to 15 minutes.

# Perimetral bathroom fans, with unique automatic shutter system. X-MART MATIC / X-MART MATIC INOX



STAINLESS STEEL  
VERSION

- **Automatic shutter** system.
- Recessed and **design** of a new generation.
- **QUICK FIX GRIP**, exclusive mounting system
- **Front cover easy to dismantle without using any tools**, easy cleaning.
- Plastic housing, impeller and led.
- 220-240V 50/60Hz motors, insulation class **B** and thermal cut out, ambient temperature max. 40°C.
- Pilot light operation
- Finishes: White / Stainless Steel.



QUICK  
FIX GRIP



AUTOMATIC  
SHUTTER  
SYSTEM



EASY-TO-CLEAN  
REMOVABLE  
COVER

CODE	MODEL	EAN CODE	VERSION	Ø (mm)	Speed (r.p.m)	Input Power (W)	Maximum AirFlow (m³/h)	Sound Pressure Level dB(A)	Weight (kg)	Units per box
<b>TIMER SERIES</b>										
01016000	X-MART 10 MATIC T	8422248003551	●	100	2500	15	98	38	0,65	10
01026000	X-MART 12 MATIC T	8422248003582	●	120	2450	20	190	40	0,82	5
01046000	X-MART 10 MATIC INOX T	8422248003735	●	100	2500	15	98	38	0,78	10
01056000	X-MART 12 MATIC INOX T	8422248003766	●	120	2450	20	190	40	0,98	5
01066000	X-MART 15 MATIC INOX T	8422248003797	●	150	2100	25	320	42	1,14	5
<b>STANDAR SERIES</b>										
01015000	X-MART 10 MATIC	8422248003544	●	100	2500	15	98	38	0,65	10
01025000	X-MART 12 MATIC	8422248003575	●	120	2450	20	190	40	0,82	5
01035000	X-MART 15 MATIC	8422248003605	●	150	2100	25	320	42	0,97	5
01045000	X-MART 10 MATIC INOX	8422248003728	●	100	2500	15	98	38	0,78	10
01055000	X-MART 12 MATIC INOX	8422248003759	●	120	2450	20	190	40	0,98	5
01065000	X-MART 15 MATIC INOX	8422248003780	●	150	2100	25	320	42	1,14	5

## DIMENSIONS mm

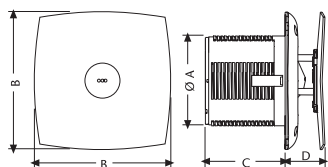

	Ø A	B	C	D
X-MART MATIC 10	98	150	87	38 máx.
X-MART MATIC 12	118	170	101	38 máx.
X-MART MATIC 15	148	194	120	38 máx.

## Versions



**STANDARD**  
In combination with light, fans switches on.



**TIMER**  
Electronic timer adjustable from 3 to 15 minutes.

Axial fans for bathrooms, with short tube, to be installed in ceiling, wall or window.

# B-MATIC

SHORT  
TUBE



AUTOMATIC  
SHUTTER

- With **automatic shutter**.
- White finish.
- Plastic housing and impeller.
- 220-240V 50/60Hz motors, insulation class **B** and thermal cut out, ambient temperature max. 40°C.

CODE	MODEL	EAN CODE	VERSION	Ø (mm)	Speed (r.p.m)	Input Power (W)	Maximum AirFlow (m³/h)	Sound Pressure Level dB(A)	Weight (kg)	Units per box
<b>SERIE TIMER</b>										
00916000	<b>B-10 MATIC T</b>	8422248110303	●	100	2500	15	98	41	0,70	5
00926000	<b>B-12 MATIC T</b>	8422248110808	●	120	2450	20	190	43	0,90	5
<b>SERIE ESTANDAR</b>										
00915000	<b>B-10 MATIC</b>	8422248110204	●	100	2500	15	98	41	0,70	5
00925000	<b>B-12 MATIC</b>	8422248110709	●	120	2450	20	190	43	0,90	5
00935000	<b>B-15 MATIC</b>	8422248111102	●	150	2100	28	320	43	1,20	5

## DIMENSIONS mm

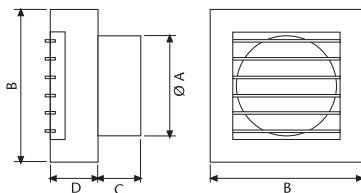

	Ø A	B	C	D
B-10 MATIC	98	150	42	47
B-12 MATIC	118	180	45	56
B-15 MATIC	148	209	60	58

## Versions



**STANDARD**  
In combination with light, fans switches on.



**TIMER**  
Electronic timer adjustable from 3 to 15 minutes.

# Perimetral bathroom fans. X-MART / X-MART INOX



STAINLESS STEEL  
**VERSION**

- Aerodynamic and cutting-edge **design**.
- **QUICK FIX GRIP**, exclusive mounting system.
- **Backdraught shutters incorporated**.
- **Front cover easy to dismantle without using any tools**, easy cleaning.
- 220-240V 50/60Hz motors, insulation class **B** and thermal cut out, ambient temperature max. 40°C.
- Plastic housing, impeller and led.
- Pilot light operation
- Finishes: White / Stainless Steel.

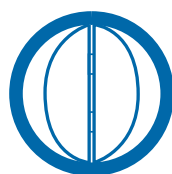

BACKDRAUGHT  
SHUTTERS



QUICK  
FIX GRIP



EASY-TO-CLEAN  
REMOVABLE  
COVER

CODE	MODEL	EAN CODE	VERSION	Ø (mm)	Speed (r.p.m)	Input Power (W)	Maximum AirFlow (m³/h)	Sound Pressure Level dB(A)	Weight (kg)	Units per box
<b>HYGRO SERIES</b>										
01044000	X-MART 10 INOX H	8422248003650	●	100	2500	15	98	38	0,66	5
01054000	X-MART 12 INOX H	8422248003681	●	120	2450	20	190	40	0,87	5
01064000	X-MART 15 INOX H	8422248003711	●	150	2100	25	320	42	1,04	5
<b>TIMER SERIES</b>										
01011000	X-MART 10 T	8422248003414	●	100	2500	15	98	38	0,64	10
01021000	X-MART 12 T	8422248003438	●	120	2450	20	190	40	0,84	5
01041000	X-MART 10 INOX T	8422248003643	●	100	2500	15	98	38	0,66	10
01051000	X-MART 12 INOX T	8422248003674	●	120	2450	20	190	40	0,87	5
01061000	X-MART 15 INOX T	8422248003704	●	150	2100	25	320	42	1,04	5
<b>STANDAR SERIES</b>										
01010000	X-MART 10	8422248003384	●	100	2500	15	98	38	0,64	10
01020000	X-MART 12	8422248003391	●	120	2450	20	190	40	0,84	5
01030000	X-MART 15	8422248003407	●	150	2100	25	320	42	1,02	5
01040000	X-MART 10 INOX	8422248003636	●	100	2500	15	98	38	0,66	10
01050000	X-MART 12 INOX	8422248003667	●	120	2450	20	190	40	0,87	5
01060000	X-MART 15 INOX	8422248003698	●	150	2100	25	320	42	1,04	5

## DIMENSIONS mm

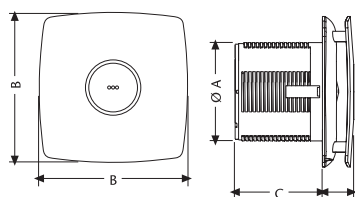

	Ø A	B	C	D
X-MART 10	98	150	89,5	31
X-MART 12	118	170	103,5	32
X-MART 15	148	194	123,5	34

## Versions



**STANDARD**  
In combination with light, fans switches on.



**TIMER**  
Electronic timer adjustable from 3 to 15 minutes.



**HYGRO**  
Adjustable humidity detector from 40% to 90%, and adjustable electronic timer from 40 seconds to 15 minutes.

Completely built-in bathroom fans with perimetral and central extraction system, high-performance and low noise level.

## SILENTIS / SILENTIS INOX



STAINLESS STEEL  
VERSION

- Cutting-edge **design**.
- **Backdraught shutters incorporated**.
- Front cover easy to dismantle and to clean.
- Plastic housing and impeller and led.
- 220-240V 50/60Hz motors, protection **IP-X4** insulation class **B** and thermal cut out, ambient temperature max. 40°C.
- Finishes: White / Stainless Steel.



VERY  
SILENT



EASY-TO-CLEAN  
REMOVABLE  
COVER

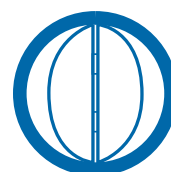

BACKDRAUGHT  
SHUTTERS

CODE	MODEL	EAN CODE	VERSION	Ø (mm)	Speed (r.p.m)	Input Power (W)	Maximum AirFlow (m³/h)	Sound Pressure Level dB(A)	Weight (kg)	Units per box
<b>SERIE TIMER</b>										
01073000	SILENTIS LN 10 T	8422248070379	●	100	2300	12	90	30	0,64	10
01073300	SILENTIS LN 10 INOX T	8422248070386	●	100	2300	12	90	30	0,64	10
01071000	SILENTIS 10 T	8422248016940	●	100	2500	15	98	37	0,64	10
01071300	SILENTIS 10 INOX T	8422248016964	●	100	2500	15	98	37	0,64	10
01081300	SILENTIS 12 INOX T	8422248017008	●	120	2450	20	190	39	0,85	5
<b>STANDAR SERIES</b>										
01072000	SILENTIS LN 10	8422248070355	●	100	2300	12	90	30	0,64	10
01072300	SILENTIS LN 10 INOX	8422248070362	●	100	2300	12	90	30	0,64	10
01070000	SILENTIS 10	8422248016643	●	100	2500	15	98	37	0,64	10
01080000	SILENTIS 12	8422248016971	●	120	2450	20	190	39	0,85	5
01090000	SILENTIS 15	8422248017015	●	150	2100	25	320	41	1,02	5
01070300	SILENTIS 10 INOX	8422248016957	●	100	2500	15	98	37	0,64	10
01080300	SILENTIS 12 INOX	8422248016995	●	120	2450	20	190	39	0,85	5

### DIMENSIONS mm

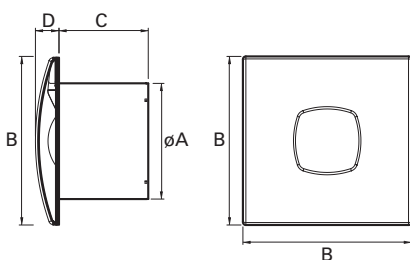

	Ø A	B	C	D
SILENTIS 10	98	140	80	22
SILENTIS 12	118	170	95	30
SILENTIS 15	148	190	112	32

### Versions



**STANDARD**  
In combination with light, fans switches on.



**TIMER**  
Electronic timer adjustable from 3 to 15 minutes.

# Axial fans for bathrooms, very slim, to be installed in ceiling or wall.

## B-PLUS



SLIM

- Very slim, recessed design.
- Plastic housing and impeller.
- 220-240V 50/60Hz motors, insulation class **B** and thermal cut out, ambient temperature max. 40°C.
- Light sensor in **HUMIDISTAT** version and **B15 PLUS** models.



CODE	MODEL	EAN CODE	VERSION	Ø (mm)	Speed (r.p.m)	Input Power (W)	Maximum AirFlow (m³/h)	Sound Pressure Level dB(A)	Weight (kg)	Units per box
<b>SERIE HYGRO</b>										
00981401	<b>B10 PLUS H</b>	8422248050876	●	100	2500	15	98	41	0,6	10
<b>SERIE TIMER</b>										
00981101	<b>B10 PLUS T</b>	8422248049566	●	100	2500	15	98	41	0,6	10
00982100	<b>B12 PLUS T</b>	8422248113489	●	120	2450	20	190	43	0,8	5
00983100	<b>B15 PLUS T</b>	8422248114257	●	150	2100	28	320	43	0,9	5
<b>SERIE ESTANDAR</b>										
00990000	<b>B8 PLUS</b>	8422248113168	●	90	2500	15	70	39	0,57	10
00281000	<b>STOCK B10 PLUS</b>	8422248047210	●	100	2500	15	98	41	0,6	10
00282000	<b>STOCK B12 PLUS</b>	8422248053969	●	120	2450	20	190	43	0,8	5
00283000	<b>STOCK B15 PLUS</b>	8422248047227	●	150	2100	28	320	43	0,9	5
00981001	<b>SPECIAL B10 PLUS</b>	8422248047906	●	100	2500	15	98	41	0,6	10
00982000	<b>SPECIAL B12 PLUS</b>	8422248113472	●	120	2450	20	190	43	0,8	5
00983000	<b>SPECIAL B15 PLUS</b>	8422248114226	●	150	2100	28	320	43	0,9	5

### DIMENSIONS mm

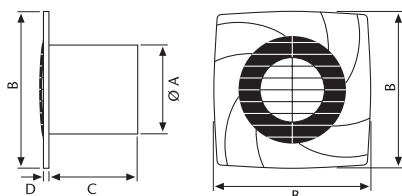

	Ø A	B	C	D
B-8 PLUS	86	140	88	10
B-10 PLUS	98	140	85	10
B-12 PLUS	118	170	100	13
B-15 PLUS	148	190	112	15

### Versions



**STANDARD**  
In combination with light, fans switches on.



**TIMER**  
Electronic timer adjustable from 3 to 15 minutes.



**HYGRO**  
Adjustable humidity detector from 40% to 90%, and adjustable electronic timer from 40 seconds to 15 minutes.



Axial fans for bathrooms with short tube for wall, ceiling and glass (using Glass Kit accessory).

## B



**SHORT TUBE**

- White finishing.
- Plastic housing and impeller.
- 220-240V 50/60Hz motor, insulation class **B** as thermal cut out, ambient temperature max. 40°C.
- Neon light sensor in humidistat versions.

CODE	MODEL	EAN CODE	VERSION	Ø (mm)	Speed (r.p.m)	Input Power (W)	Maximum AirFlow (m³/h)	Sound Pressure Level dB(A)	Weight (kg)	Units per box
<b>SERIE TIMER</b>										
00911000	B-10 T	8422248110105	●	100	2500	15	98	41	0,60	10
<b>SERIE ESTANDAR</b>										
00910000	B-10	8422248110006	●	100	2500	15	98	41	0,60	10
00920000	B-12	8422248110501	●	120	2450	20	190	43	0,85	5
00930000	B-15	8422248110907	●	150	2100	28	320	43	0,95	5

### DIMENSIONS mm

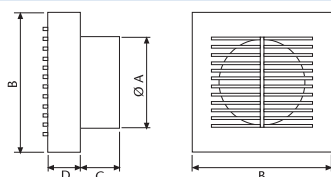

	Ø A	B	C	D
B-10	98	150	42	35
B-12	118	180	45	44
B-15	148	209	60	45

Axial fans for bathrooms with infra-red sensor.

## B-PIR



**PIR: INFRA RED SENSOR ACTIVATED BY PRESENCE**



**SHORT TUBE**

- Fitted with infra-red sensor activated by presence.
- Timer (electronic timer adjustable from 3 to 15 minutes).
- White finishing.
- Plastic housing and impeller.
- 220-240V 50/60Hz motor, insulation class **B** as thermal cut out, ambient temperature max. 40°C.

CODE	MODEL	EAN CODE	Ø (mm)	Speed (r.p.m)	Input Power (W)	Maximum AirFlow (m³/h)	Sound Pressure Level dB(A)	Weight (kg)	Units per box
00913000	B-10 PIR	8422248112123	100	2500	15	98	41	0,60	4

### DIMENSIONS mm

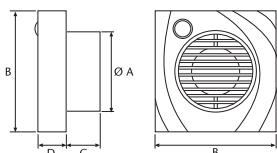

	Ø A	B	C	D
B-10 PIR	98	150	42	35

### Versions



**STANDARD**  
In combination with light, fans switches on.



**TIMER**  
Electronic timer adjustable from 3 to 15 minutes.



**PIR**  
Infra red sensor activated by presence and adjustable electronic timer from 40 seconds to 15 minutes.

# CENTRIFUGAL BATHROOM FANS

High-performance centrifugal bathroom fans, slim version, to be installed in ceilings or walls.

## CB-100 PLUS / CB-250 PLUS



CB-100 PLUS



CB-250 PLUS

- **CB-100 PLUS** totally recessed.
- Finishing: white.
- **CB-250** with short tube.
- Modern slim version.
- Centrifugal impeller for high pressure, which need to be passed in longer ductings.
- **Backdraught shutters included.**
- Plastic housing and impeller.
- 220-240V 50/60Hz motors (CB-100 PLUS), insulation class **B** and thermal cut out, ambient temperature max. 40°C.
- 230V 50Hz motors (CB-250 PLUS), insulation class thermal cut out, ambient temperature max. 40°C.
- 60Hz versions on demand.

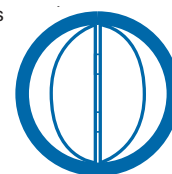

BACKDRAUGHT SHUTTERS

CODE	MODEL	EAN CODE	VERSION	Ø (mm)	Speed (r.p.m)	Input Power (W)	Maximum AirFlow (m³/h)	Sound Pressure Level dB(A)	Weight (kg)	Units per box
<b>TIMER SERIES</b>										
00841000	CB-100 PLUS T	8422248114394	●	100	2300	25	130	49	0,98	5
<b>STANDARD SERIES</b>										
00840000	CB-100 PLUS	8422248114387	●	100	2300	25	130	49	0,98	5
00850000	CB-250 PLUS	8422248114417	●	100/120	2300	45	270	52	1,64	5

### DIMENSIONS mm

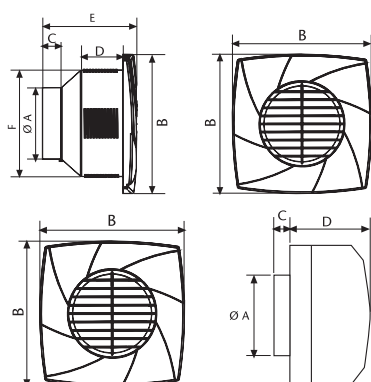

	Ø A	B	C	D	E	F
CB-100 PLUS	97,6	190	26	57,4	129,4	147,8

	Ø A	B	C	D
CB-250 PLUS	96/118	208	17	122

\* Double outflow diameter included.

### Versions



**STANDARD**  
In combination with light, fans switches on.



**TIMER**  
Electronic timer adjustable from 3 to 15 minutes.

# IN-LINE DUCT FANS

In-line mixed flow fans with high performance air flow capacity and low noise level.

## DUCT IN-LINE

EASY  
MAINTENANCE

2 SPEED

3 SPEED

DUCT IN LINE 200 STANDAR

IP-44



### Fan:

- Housing polypropylene plastic.
- Easy accessible motor due to the motor support, which can be dismantled without interfering existing duct system. (1)

### Motor:

- Asynchronous 1, 2 and 3 speeds motor, self-lubricating bearings for life.
- Protection **IP44** (not **DUCT IN-LINE 100/130**) insulation Class **B**, and thermal cut out, ambient temperature max. 60°C.
- External terminal box.
- 60Hz versions on demand.
- Speed control possible (not timer versions).
- **TIMER** version models adjustable from 3 to 15 minutes.

### Impeller:

- High performance and very silence helicocentrifugal mixed flow, made in ABS plastic.
- **DUCT IN-LINE 100/130** with centrifugal impeller.

### Accessories:

- Fixed plastic grills.

CODE	MODEL	EAN CODE	Speed (r.p.m)	Input Power (W)	Max. Amps (A)	AirFlow (m³/h)	Sound Pressure Level dB(A)	Weight (kg)
<b>SERIE TIMER</b>								
00702100	DUCT IN-LINE 100/270 T	8422248021210	2.300/1.700	28/18	0,18/0,10	270/190	30/24	2,1
00703100	DUCT IN-LINE 125/320 T	8422248021234	2.300/1.700	28/18	0,18/0,10	365/250	32/26	2,1
<b>SERIE ESTANDAR</b>								
00770000	DUCT IN-LINE 100/130	8422248920735	2.200	25	0,16	130	24	1,2
00702000	DUCT IN-LINE 100/270	8422248021203	2.300/1.700	28/18	0,18/0,10	270/190	30/24	2,1
00703000	DUCT IN-LINE 125/320	8422248021227	2.300/1.700	28/18	0,18/0,10	365/250	32/26	2,1
00704000	DUCT IN-LINE 150/560	8422248021241	2.700/2.000	80/60	0,36/0,27	595/420	33/27	3,2
00705000	DUCT IN-LINE 160/560	8422248021265	2.700/2.000	80/60	0,36/0,27	595/420	33/27	3,2
00706000	DUCT IN-LINE 200/910	8422248021289	2.700/2.000/1.800	85/65/55	0,34/0,27/0,24	910/820/720	39/34/32	4,5

### DIMENSIONS mm

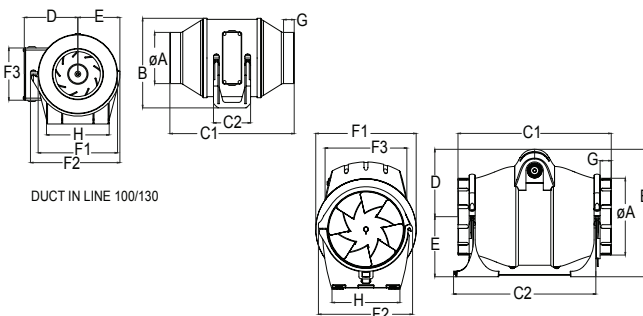

	Ø A	B	C1	C2	D	E	F1	F2	F3	G	H
DUCT IN LINE 100/130	98	171,5	238	71	102,5	80,5	152	171	100	20	120
DUCT IN LINE 100/270	98	232	315	241,6	117	115	168	180	155	25	130
DUCT IN LINE 125/320	122	232	279	241,6	117	115	168	180	155	25	130
DUCT IN LINE 150/560	147	244	293,4	272,4	129	115	192	180	158	21	130
DUCT IN LINE 160/560	157	244	312,6	272,4	129	115	192	180	158	23	130
DUCT IN LINE 200/910	197	278,5	353,6	272,4	138,5	140	211	230	161,5	51,5	142

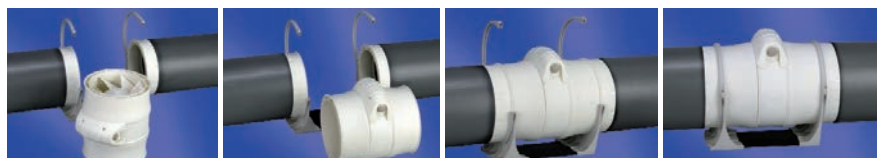

Duct fans for installation in rigid and flexible tubes.

MT

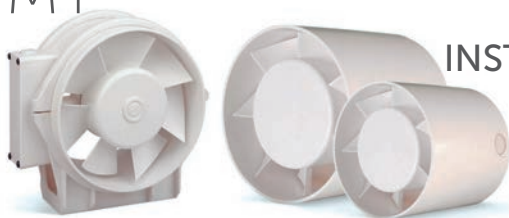

EASY  
INSTALLATION

- Very silent fans.
- Plastic housing and impeller.
- All models and versions fitted with 220-240V 50/60Hz motors, **IP-X2** protection and class **B** as standard.
- Mounting support for 100 and 100 T is optional.
- White finishing.

CODE	MODEL	EAN CODE	VERSION	Ø (mm)	Speed (r.p.m)	Input Power (W)	Maximum AirFlow (m³/h)	Sound Pressure Level dB(A)	Weight (kg)	Units per box
<b>TIMER SERIES</b>										
00711000	MT-100 T	8422248920513	●	100	2500	15	98	41	0,4	10
<b>STANDARD SERIES</b>										
00710000	MT-100	8422248920186	●	100	2500	15	98	41	0,4	10
00720000	MT-125	8422248920520	●	120	2450	20	190	43	0,6	10
00730000	MT-150	8422248920797	●	150	2100	25	320	45	1,2	5

**DIMENSIONS mm**

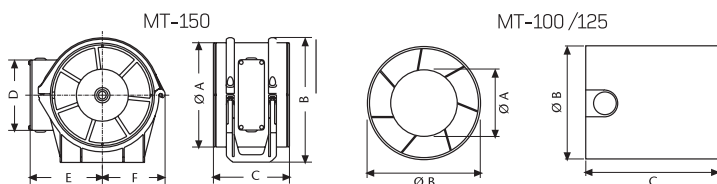

	Ø A	B	C	D	E	F
MT-100	60	97	92	-	-	-
MT-125	65	118	96	-	-	-
MT-150	148	177	108	100	99,5	89,2



Duct fans with installation kit to be installed in ductings with flexible and rigid tubes.

**KIT IN LINE**

- Composed by MT series, flexible PVC ducts and two fixed plastic grills.
- Plastic housing and impeller.

CODE	MODEL	EAN CODE	VERSION	Ø (mm)	Speed (r.p.m)	Input Power (W)	Maximum AirFlow (m³/h)	Sound Pressure Level dB(A)	Weight (kg)	Units per box
<b>TIMER SERIES</b>										
00711100	KIT IN LINE 100 T	8422248920216	●	100	2500	15	98	41	1,10	10
<b>STANDARD SERIES</b>										
00710100	KIT IN LINE 100	8422248920209	●	100	2500	15	98	41	1,10	10
00720100	KIT IN LINE 120	8422248920612	●	120	2450	20	190	43	1,83	10
00730100	KIT IN LINE 150	8422248920803	●	150	2100	25	320	45	2,10	5

**DIMENSIONES**

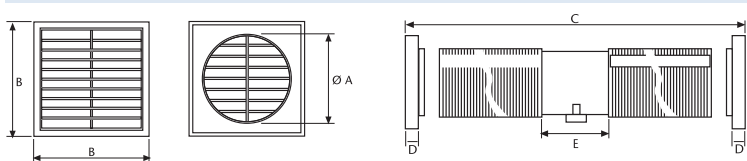

	Ø A	B	C	D	E
KIT IN LINE 100	100	140	3.000	15	92
KIT IN LINE 125	124	140	3.000	18	106
KIT IN LINE 150	150	175	3.000	15	108

**Versions**



**STANDARD**  
In combination with light, fans switches on.



**TIMER**  
Electronic timer adjustable from 3 to 15 minutes.

# WALL FANS

Helicoidal fans to be installed in walls or windows.

## LHV

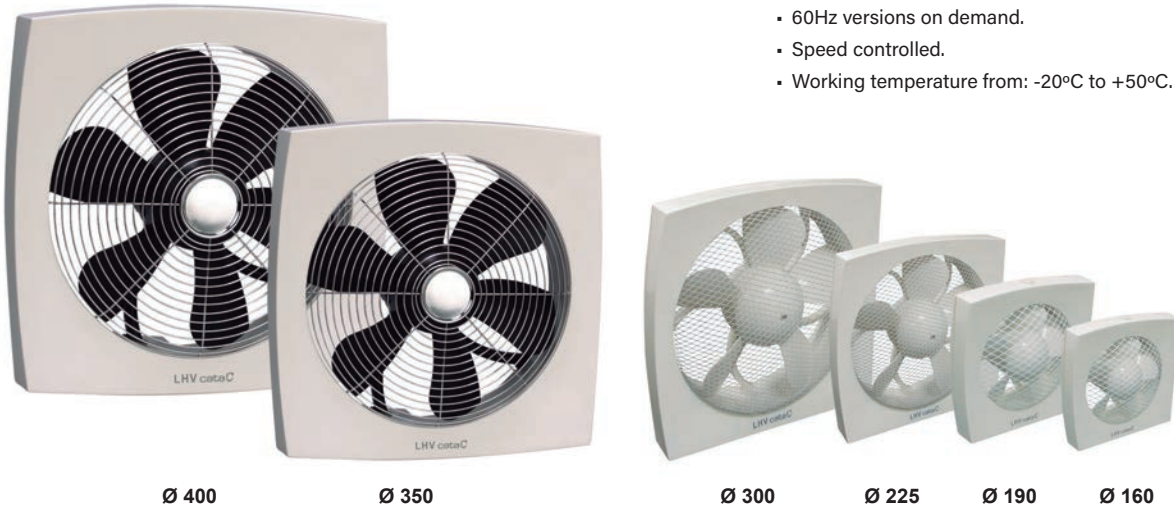

- Modern design.
- Impeller with low **noise profile and high efficiency**.
- **Window kit included**.
- Protection guard on inlet side.
- Series with 230 V, 50 motor, protection **IP-44**, insulation class **B** (type 160 IP-X4).
- 60Hz versions on demand.
- Speed controlled.
- Working temperature from: -20°C to +50°C.

CODE	MODEL	EAN CODE	Ø (mm)	Speed (r.p.m)	Input Power (W)	Maximum AirFlow (m <sup>3</sup> /h)	Sound Pressure Level dB(A)	Weight (kg)	Units per box
00660000	LHV 160	8422248009324	160	1750	20	450	40	1,2	1
00661000	LHV 190	8422248009331	190	1500	28	700	42	1,7	1
00662000	LHV 225	8422248009348	225	1150	45	900	44	3	1
00663000	LHV 300	8422248009355	300	1050	50	1450	47	3,4	1
00664000	LHV 350	8422248009362	350	1300	100	1850	52	4,3	1
00665000	LHV 400	8422248009379	400	1400	215	3150	55	7,4	1

### DIMENSIONS mm

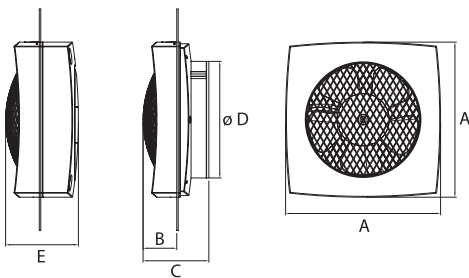

	A	B	C	Ø D	E
LHV 160	210	46	89	160	99
LHV 190	250	54	97	194	109
LHV 225	285	61	110	229	123
LHV 300	370	77	125	315	144
LHV 350	430	85	142	365	159
LHV 400	490	95	160	415	181

Helicoidal fans to be installed in walls or windows.

# B-23 / B-30



REVERSIBLE  
FAN  
AUTOMATIC  
SHUTTER SYSTEM

- Elegant design.
- **Glass installation kit included as standard.**
- Protection guard on inlet side.
- Fitted with 230V 50 Hz motors and class **B** as standard.
- Fully adjustable.
- Working temperatures from -20°C to +50°C.
- Model **B**: MATIC (with automatic blind).
- **RA**: Reversible with 5-speed adjuster.

CODE	MODEL	EAN CODE	Ø (mm)	Speed (r.p.m)	Input Power (W)	Max. Amps (A)	Maximum AirFlow (m³/h)		Sound Pressure Level dB(A)	Weight (kg)	Units per box
							extract	intake			
00610000	<b>B-23</b>	8422248120234	230	1350	45	0,19	825	530	49	5,19	1
00620000	<b>B-30</b>	8422248120241	305	1260	90	0,39	1900	700	51	7,45	1
00611003	<b>B-23 RA</b>	8422248007740	230	1350	45	0,19	825	530	49	5,19	1
00621003	<b>B-30 RA</b>	8422248007764	305	1260	90	0,39	1900	700	51	7,45	1

### DIMENSIONS mm

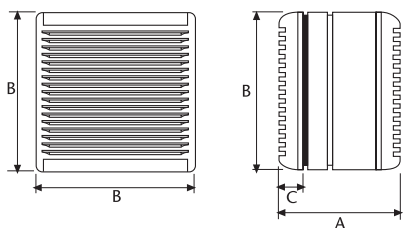

	A	B	C
B-23/RA	190	340	40
B-30/RA	230	420	40

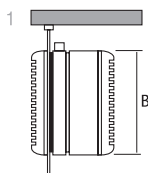

# KITCHEN EXTRACTION

Centrifugal extract fan for kitchens.

## PROFESSIONAL 750 / 750L / 500

EASY  
INSTALLATION

EXCELLENT  
PERFORMANCE

WASHABLE  
FILTERS

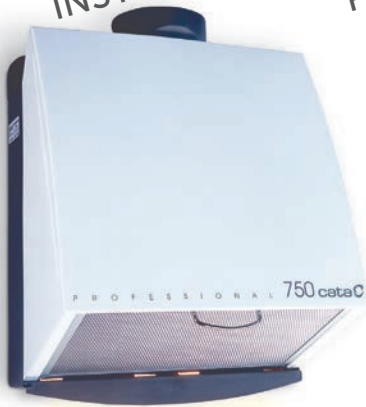

PROFESSIONAL 750/750L



PROFESSIONAL 500

- High air flow capacity.
- High efficient centrifugal impeller.
- Metal grease filter.
- **Easy to install and clean.**
- 750 model with metal housing and plastic impeller.
- 500 model with plastic housing and impeller.
- Energy class: C (model PROFESSIONAL 750)  
E (model PROFESSIONAL 750L)  
D (model PROFESSIONAL 500)



Lámparas  
2 x 28W  
modelo  
PROFESSIONAL 750L

CODE	MODEL	EAN CODE	Ø (mm)	Speed (r.p.m)	Input Power (W)	Maximum AirFlow (m³/h)	Sound Pressure Level dB(A)	Weight (kg)	Units per box
00117000	PROFESSIONAL 750	8422248100816	120	1.200	125	700	49	5	3
00117100	PROFESSIONAL 750 L	8422248100823	120	1.200	125	700	49	5	3
00117400	PROFESSIONAL 500	8422248010832	100	1.900	150	450	57	2,09	4

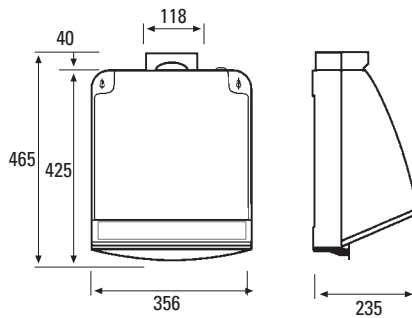

PROFESSIONAL 750/750L

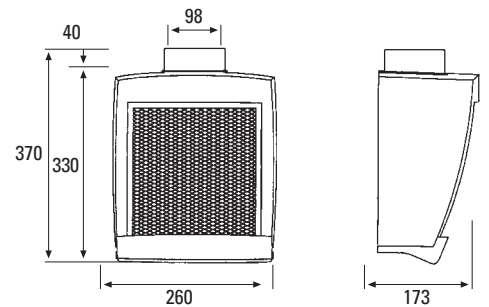

PROFESSIONAL 500

Dimensions in mm

# Centrifugal extract fan for kitchens. 600 PLUS 2V / GS 600



- High air flow capacity.
- Metal housing and high performance plastic impeller.
- Plate to collect grease.
- Easy to install and clean.
- The 600 Plus model incorporates a 2 speeds switch that can be wall mounted.
- Metallic grease filter in GS 600 PLUS and protection guard in GS 600.
- Energy class: C



CODE	MODEL	EAN CODE	Ø (mm)	Speed (r.p.m)	Input Power (W)	Maximum AirFlow (m³/h)	Sound Pressure Level dB(A)	Weight (kg)	Units per box
00116110	600 PLUS 2 VEL.	8422248006316	120	1.185	105	420/600	52	4	4
00116002	GS 600	8422248100601	110	1.180	105	480	50	4,8	4

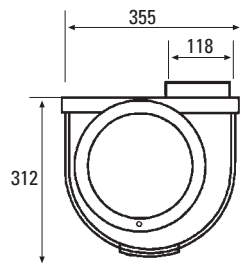

600 PLUS 2V

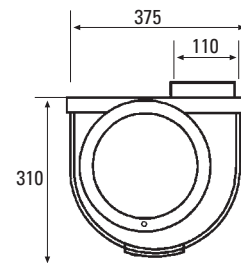
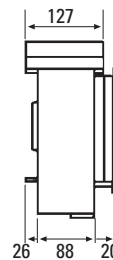

GS 600

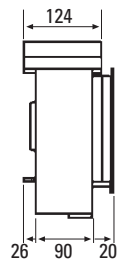

Dimensions in mm

# GS 400M / GS 400P



- GS 400 M with metal housing GS 400 P with thermal plastic housing.
- Standard protection guard in all types.
- Plate to collect grease.
- Easy to install.
- Energy class: B



CODE	MODEL	EAN CODE	Ø (mm)	Speed (r.p.m)	Input Power (W)	Maximum AirFlow (m³/h)	Sound Pressure Level dB(A)	Weight (kg)	Units per box
00114102	GS 400M	8422248100403	110	2.200	60	290	52	2,98	4
00111002	GS 400P	8422248100830	110	2.200	60	290	52	2,02	4

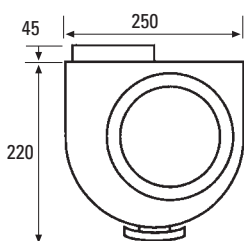

GS 400 M

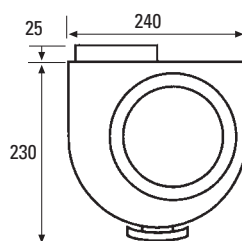

GS 400 P

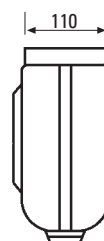

Dimensions in mm



**TECHNICAL CHARACTERISTICS KITCHEN EXTRACTION**

Models	PROFESSIONAL 750	PROFESSIONAL 750 L	PROFESSIONAL 500	600 PLUS 2V	GS 600	GS 400 M	GS 400 P
<b>Code</b>	00117000	00117100	00117400	00116110	00116002	00114102	00111002
<b>Product features according to directives</b>							
<b>EU65/2014 - EN61591, EN60704-2-13, EN50564</b>							
AEC (Annual Energy consumption) (kWh/annum)	54	155,9	73,5	54,8	51,7	29,2	30,3
EEl class (Energy Efficiency Class)	C	E	D	C	C	B	B
FDE (Fluid Dynamic Efficiency)	9,5 5,1	4,5	9,3	12,5	10,7	10,5	-
FDE class (Fluid Dynamic Efficiency Class)	E	F	F	E	E	E	E
LE (Lighting Efficiency) (lux/W)	-	1,5	-	-	-	-	-
LE class (Lighting Efficiency Class)	-	G	-	-	-	-	-
GFE (Grease Filtering Efficiency)	53,7	53,7	51,9	51,9	-	-	-
GFE Class (Grease Filtering Efficiency class)	F	F	F	F	-	-	-
Air flow at minimum speed (m3/h)	-	-	-	420	-	-	-
Air flow at maximum speed (m3/h)	600	600	450	600	480	290	290
Air flow at intensive speed (TURBO) (m3/h)	-	-	-	-	-	-	-
Sound Power Level at minimum speed (dB)	-	-	-	45	-	-	-
Sound Power Level at maximum speed (dB)	49	49	57	52	50	52	52
Sound Power Level at intensive speed (TURBO) (dB)	-	-	-	-	-	-	-
Po (Power Consumption in off mode) (W)	0	0	0	0	0	0	0
Ps (Power Consumption in standby) (W)	0	0	0	0	0	0	0
Integration directive EU 66/2014							
f (Time Increase Factor)	1,7 1,8	1,8	1,7	1,6	1,6	1,6	-
EEI (Energy Efficiency Index)	86	109,9	97,4	84,5	78,9	68,7	69,7
QBEP (Flow Rate at Best Efficiency Point) (m3/h)	287,3	287,3	128,8	285,9	311,7	163,2	174,2
PBEP (Static Pressure Difference at Best Efficiency Point) (Pa)	106 106	136,3	105	131,6	117	110,6	-
WBEP (Electric Power Input at Best Efficiency Point) (W)	89,1169,1	109,5	90,1	91,4	49,6	51,1	-
WL (Nominal Power Consumption of Lighting system) (W)	-	56	-	-	-	-	-
EMIDDLE (Average Illumination of Lighting system on Cooking surface) (lux)	-	82	-	-	-	-	-
<b>Features</b>							
Motor	INDUCCION	INDUCCION	INDUCCION	INDUCCION	INDUCCION	INDUCCION	-
Maximum Power Consumption	105W	105W	125W	105W	105W	60W	60W
Maximum Pressure	190 190	235	205	200	210	225	-
Intensive Speed (TURBO) Pressure	-	-	-	-	-	-	-
Control Type	-	-	-	CONMUTADOR	-	-	-
Automatic Switch Off	-	-	-	-	-	-	-
Electronic Filter Saturation Indicator	-	-	-	-	-	-	-
Filter Type	METALICO	METALICO	METALICO	METALICO	-	-	-
Anti-grease Filter Number	1	1	1	1	-	-	-
Inner Shield	-	-	-	-	-	-	-
<b>Extraction Capacity</b>							
Extraction Levels	1	1	1	2	1	1	1
Lighting							
Light Type	-	Incandescente	-	-	-	-	-
Adjustable Intensity Lighting	-	-	-	-	-	-	-
Nº of Lamps	-	2 X 28W	-	-	-	-	-
<b>Electric Connection</b>							
Total Rush Power (W)	105 161	125	105	105	60	60	-
Rated Voltage (V)	230	230	230	230	230	230	230
Network Frequency (Hz)	50	50	50	50	50	50	50
Electrical Insulation Class	CLASE I	CLASE I	CLASE II	CLASE I	CLASE I	CLASE I	CLASE I
Plug	-	-	-	-	-	-	-
<b>External Dimensions</b>							
Width (mm)	356	356	260	355	375	250	240
Depth (mm)	235 235	173	134	136	125	120	-
<b>Installation</b>							
Outlet Diameter (mm)	120 120	100	120	125	110	110	-
Minimum height distance to a electric worktop hob (mm)	65	65	65	65	65	65	65
Minimum height distance to a gas worktop hob (mm)	65	65	65	65	65	65	65
Installation with Outlet tube to the exterior / Recirculating	EXTERIOR	EXTERIOR	EXTERIOR	EXTERIOR	EXTERIOR	EXTERIOR	EXTERIOR
Easy Installation System	-	-	-	-	-	-	-
<b>Accessories</b>							
Metal Filter	01140700	01140700	65200040	01100000	-	-	-

DOMESTIC VENTILATION RANGE ACCESSORIES



FIXED GRILL



GRILL  
ON PRESSURE



GLASS KIT



RING FIXTURE

E-100	REF.	01910200	01910300		
E-120	REF.	01920200	01920300		
E-150	REF.	01930200	01930300		
X-MART 10	REF.	01910200	01910300	01970000	01910100
X-MART 12	REF.	01920200	01920300	01971000	01920100
X-MART 15	REF.	01930200	01930300	01972000	01930100
X-MART 10 MATIC	REF.	01910200	01910300	01970000	01910100
X-MART 12 MATIC	REF.	01920200	01920300	01971000	01920100
X-MART 15 MATIC	REF.	01930200	01930300	01972000	01930100
X-MART 10 INOX	REF.				
X-MART 12 INOX	REF.				
X-MART 15 INOX	REF.				
X-MART 10 MATIC INOX	REF.				
X-MART 12 MATIC INOX	REF.				
X-MART 15 MATIC INOX	REF.				
SILENTIS LN 10 / SILENTIS 10	REF.	01910200	01910300		
SILENTIS 12	REF.	01920200	01920300		
SILENTIS 15	REF.	01930200	01930300		
SILENTIS LN 10 INOX	REF.				
SILENTIS 12 INOX	REF.				
B-10 Plus /C (00281000) / B10 PLUS TIMER	REF.	01910200	01910300		
B-12 Plus /C (00282000)	REF.	01920200	01920300		
B-15 Plus /C (00283000)	REF.	01930200	01930300		
B-12 Plus Timer	REF.	01920200	01920300		01920100
B-15 Plus Timer	REF.	01930200	01930300	01983000	01930100
B-10	REF.	01910200	01910300	01910000	01910100
B-12	REF.	01920200	01920300	01920000	01920100
B-15	REF.	01930200	01930300	01930000	01930100
B-10 MATIC	REF.	01910200	01910300	01910000	01910100
B-12 MATIC	REF.	01920200	01920300	01920000	01920100
B-15 MATIC	REF.	01930200	01930300	01930000	01930100
B-10 PIR	REF.	01910200	01910300	01910000	01910100
CB-250 Plus	REF.	01910200 / 019220200	01910300 / 01920300		
CB-100 Plus	REF.	01910200	01910300		
MT-100	REF.	01910200	01910300		
MT-125	REF.	01920200	01920300		
MT-150	REF.	01930200	01930300		
B-23	REF.				
B-30	REF.				
B-23 RA	REF.				
B-30 RA	REF.				
DUCT IN LINE 100/130	REF.	01910200	01910300		
DUCT IN LINE 100/270	REF.	01910200	01910300		
DUCT IN LINE 125/320	REF.	01920200	01920300		
DUCT IN LINE 150/560	REF.	01930200	01930300		
LHV-160	REF.		01560160		
LHV-190	REF.		01560190		
LHV-225	REF.		01560225		
LHV-300	REF.		01560300		
LHV-350	REF.		01560350		
LHV-400	REF.		01560400		
PROFESSIONAL 750	REF.				
PROFESSIONAL 500	REF.				
GS-600 Plus 2V	REF.				



**cata** 

# PERFORMANCE CURVES

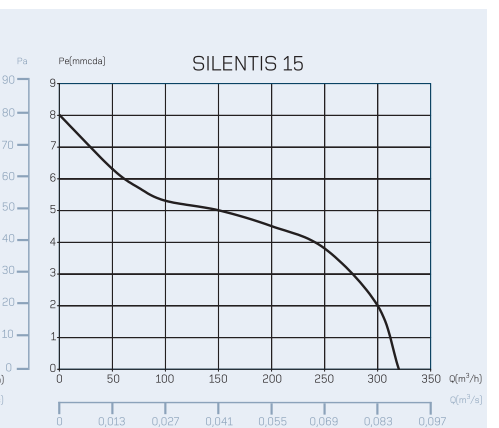
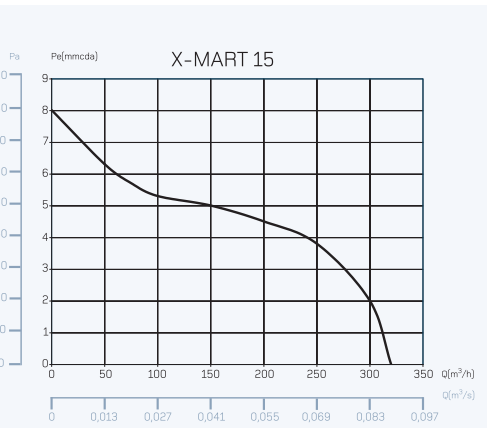
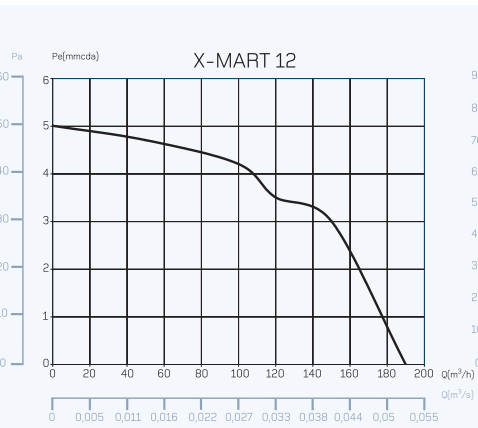
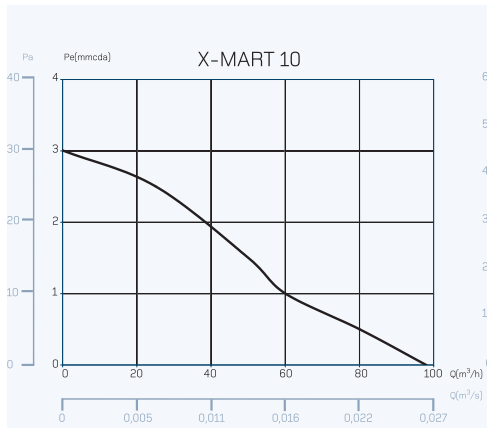
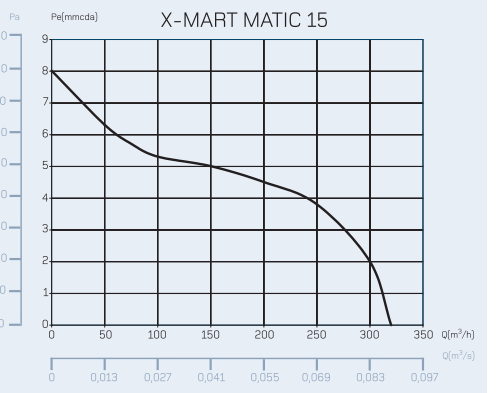
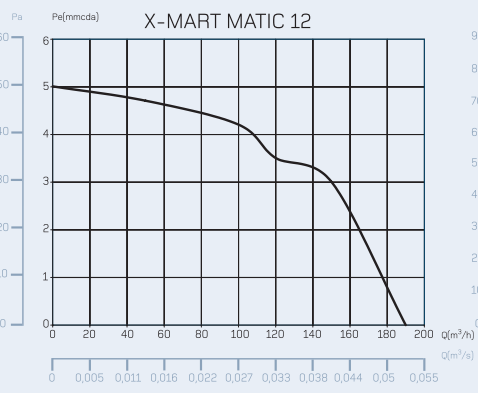
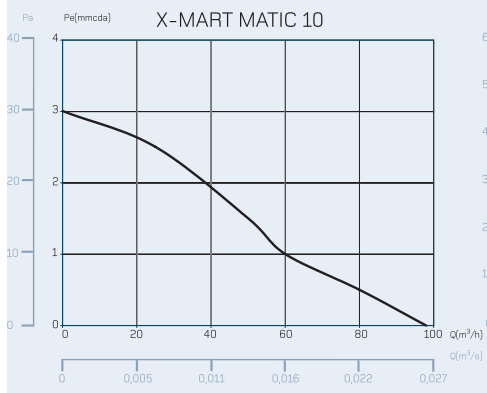
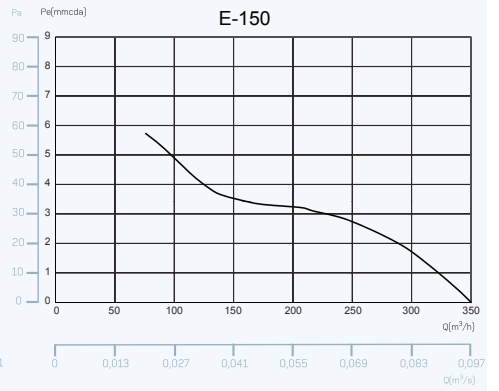
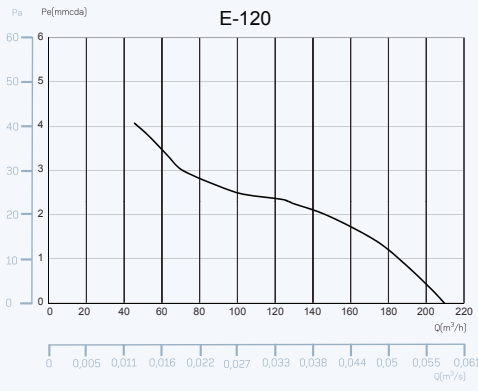
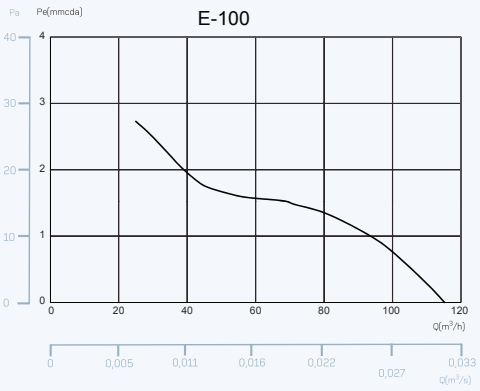

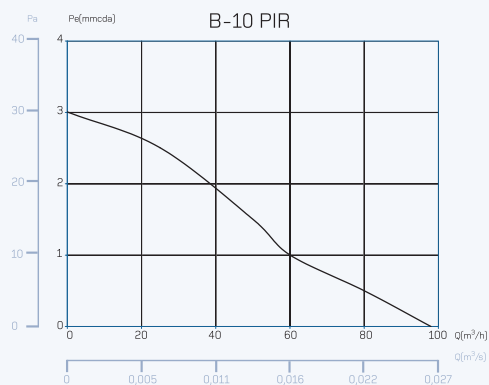
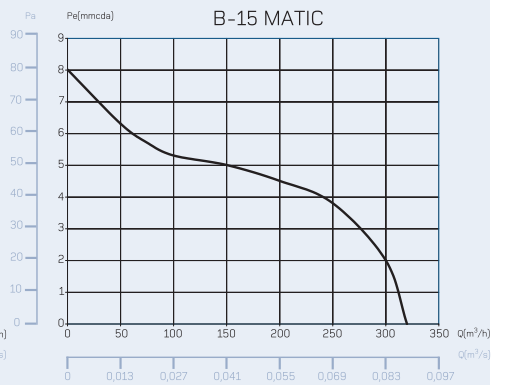
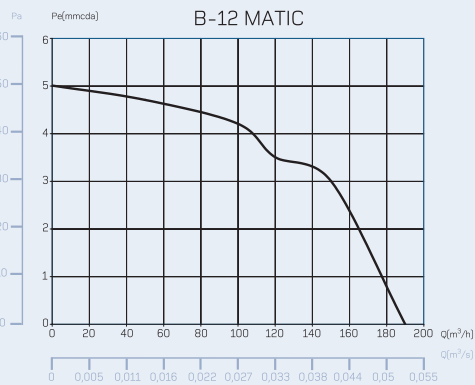
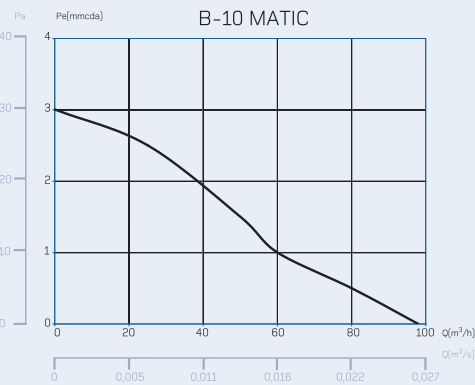
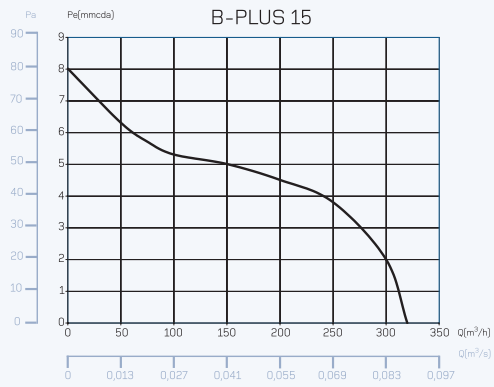
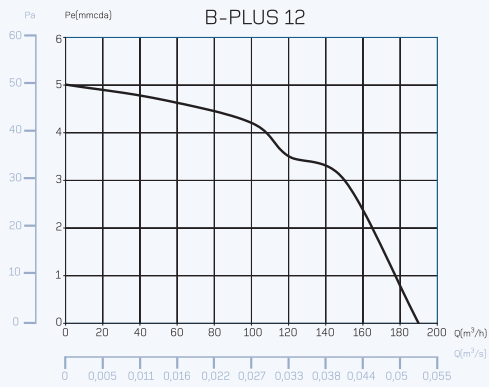
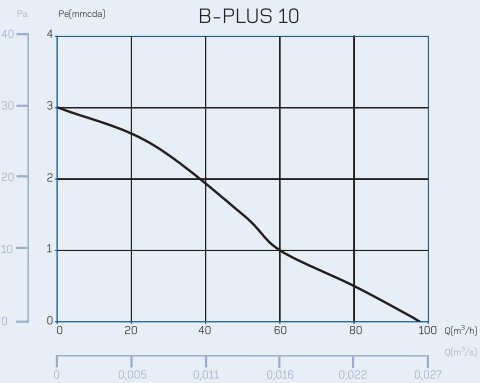
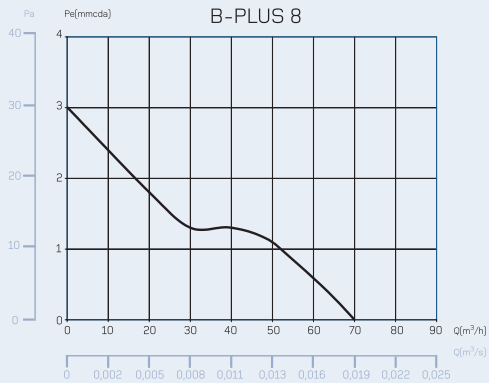

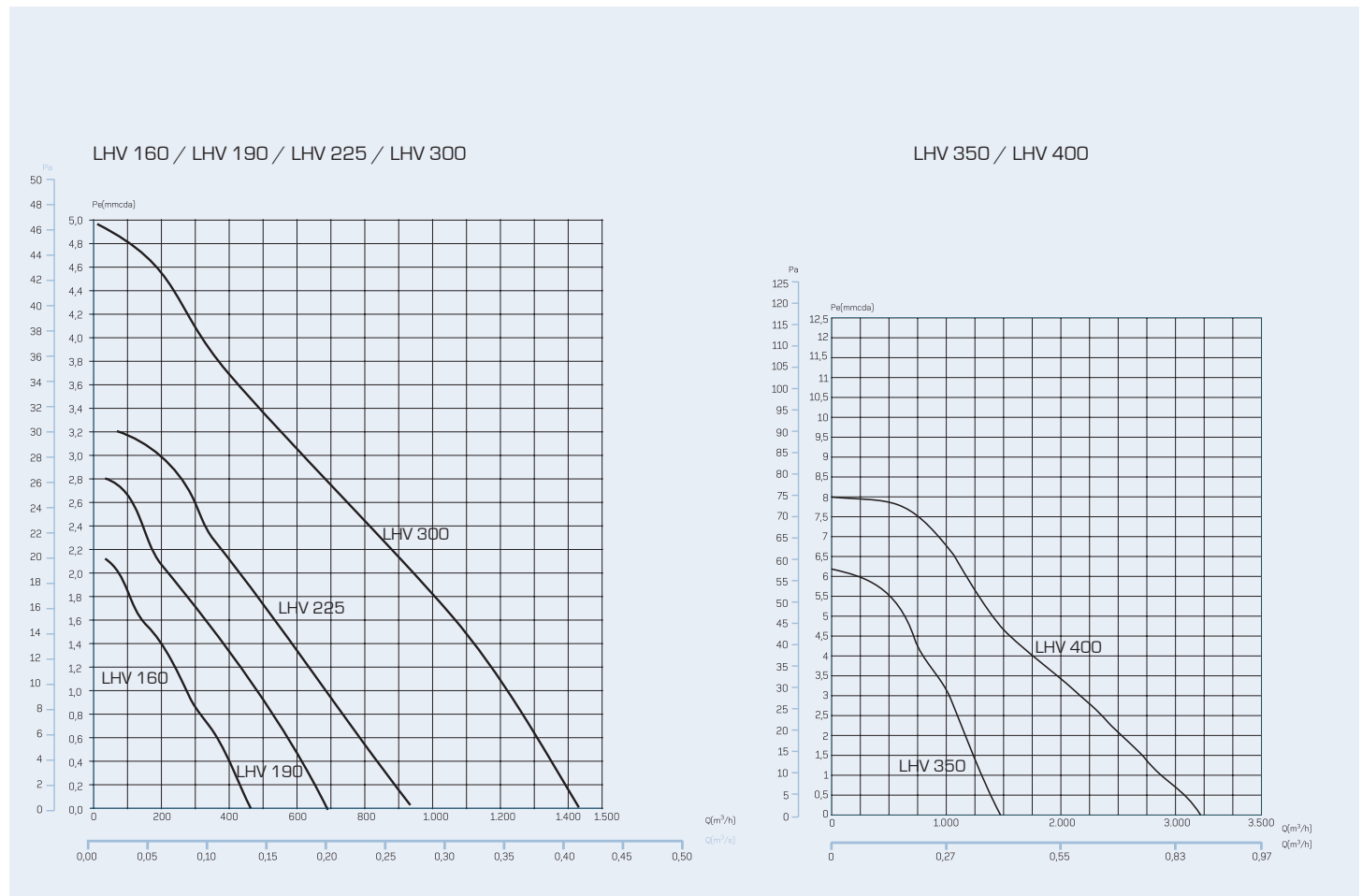
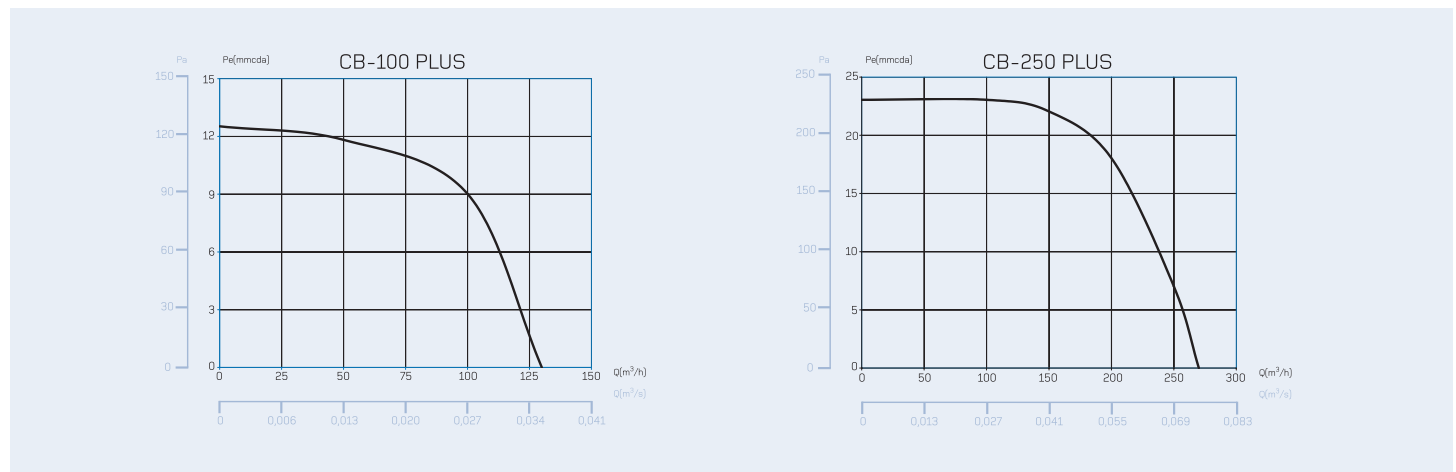
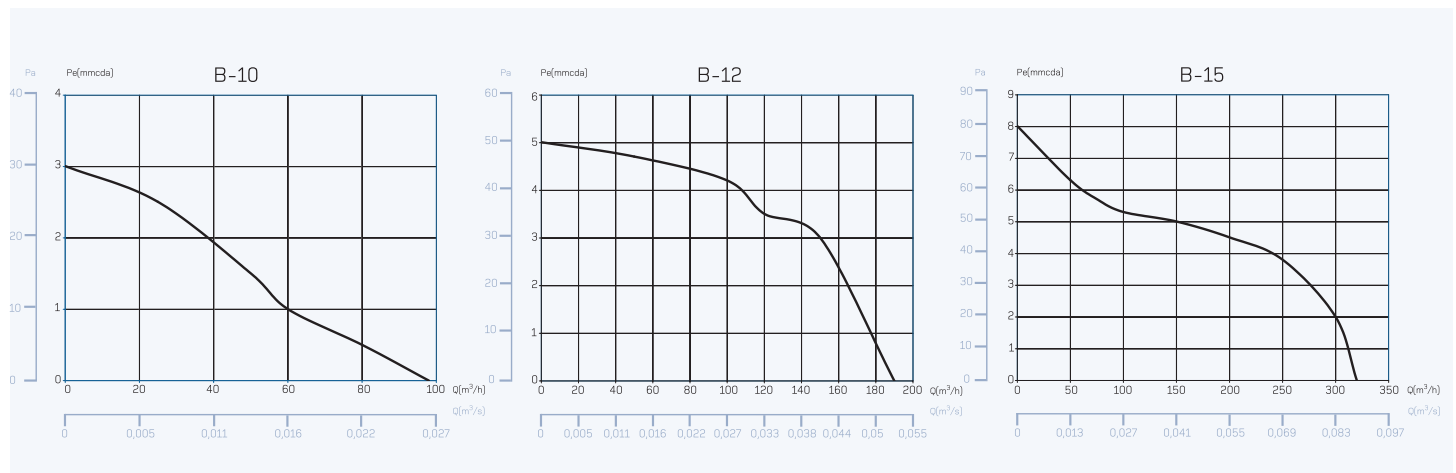

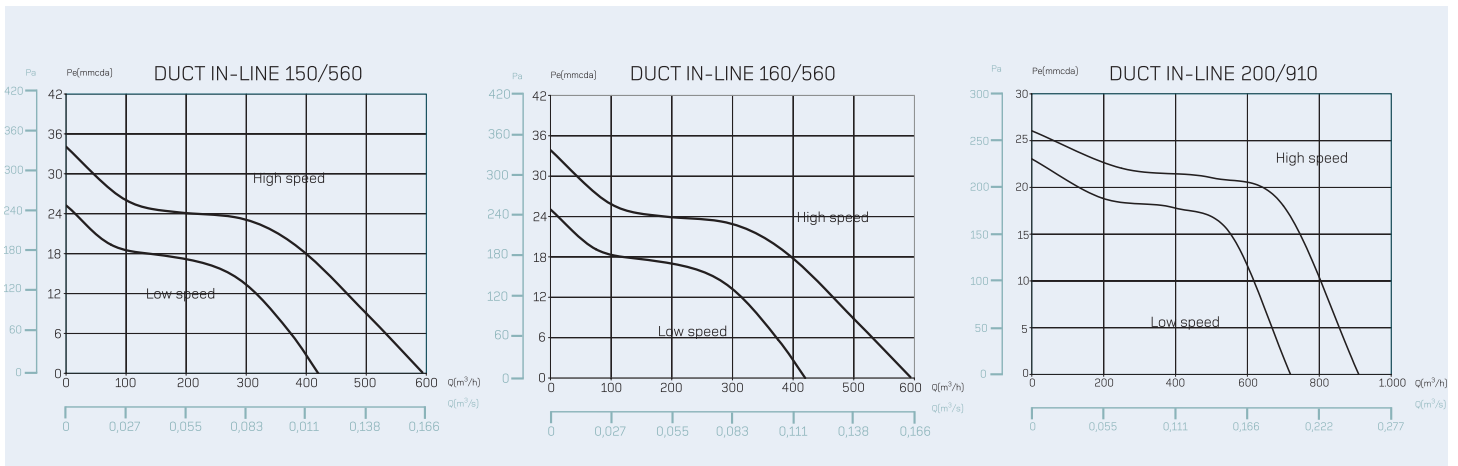
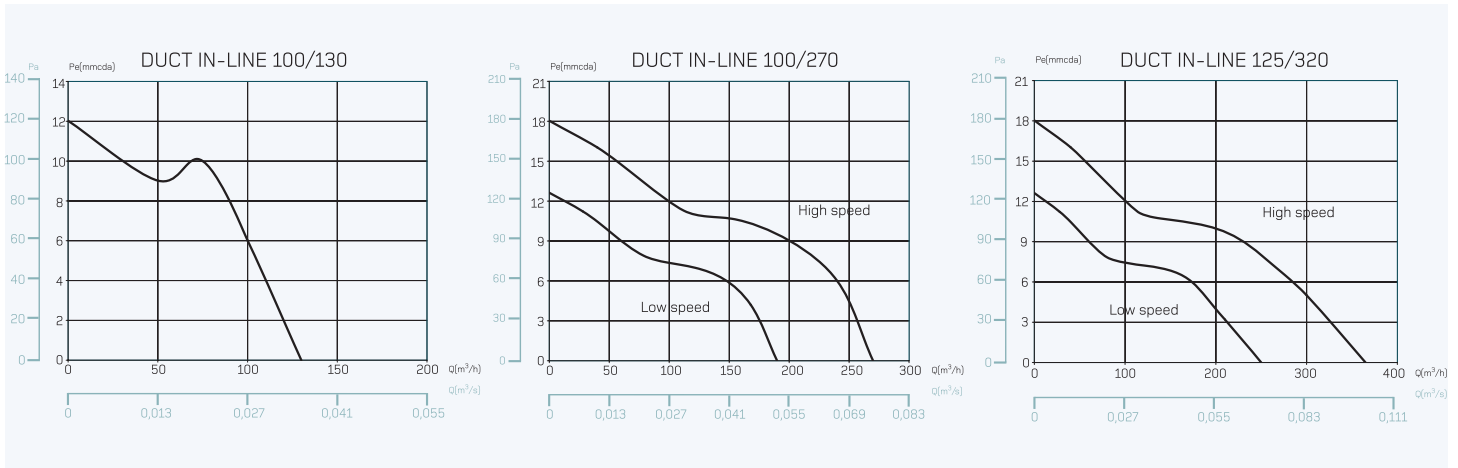
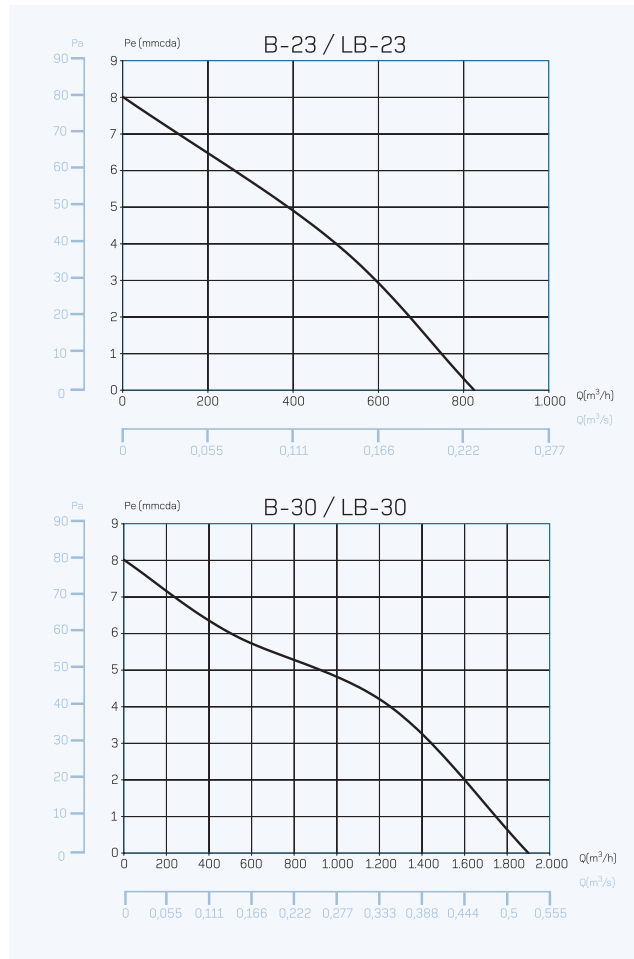



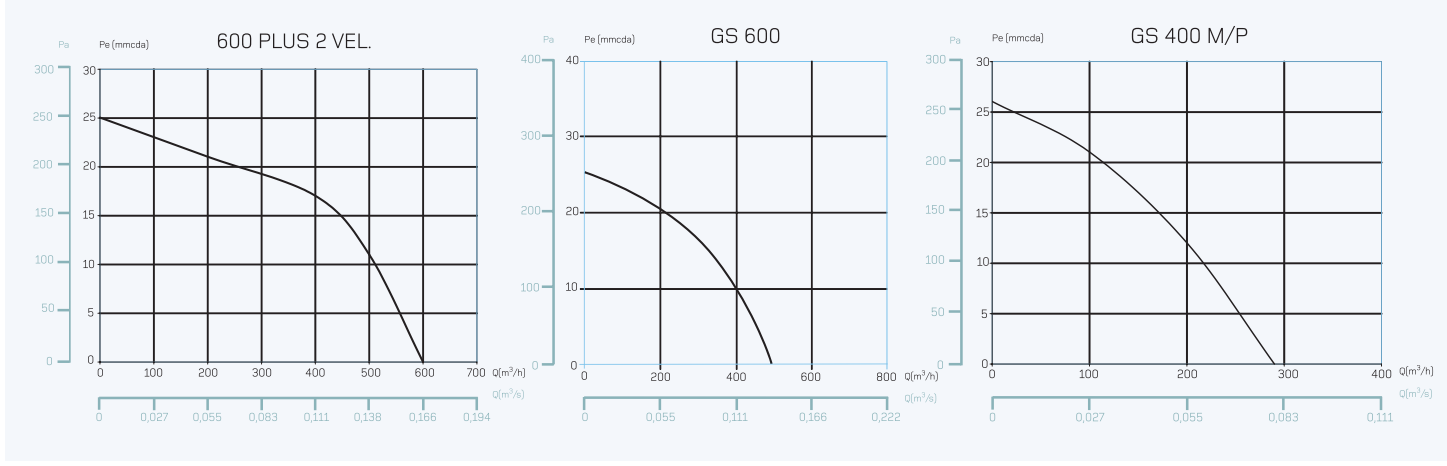
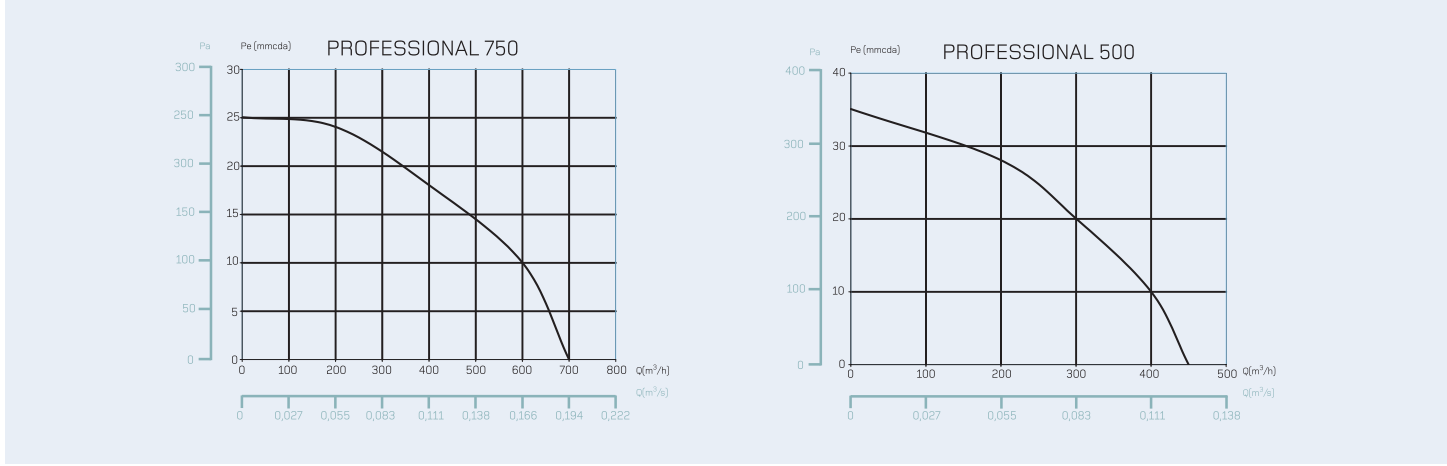
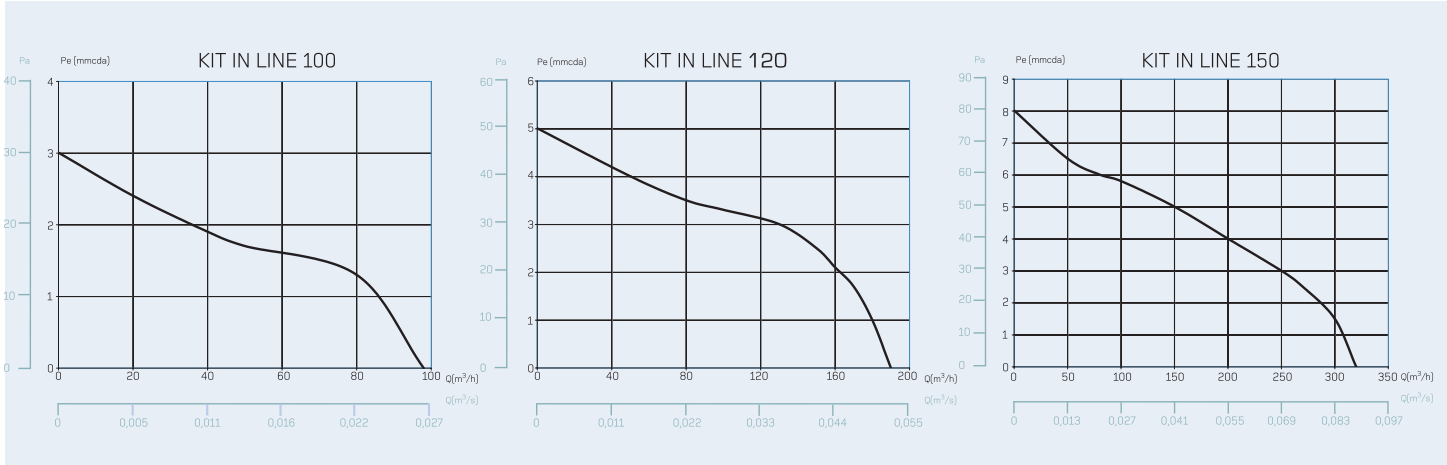
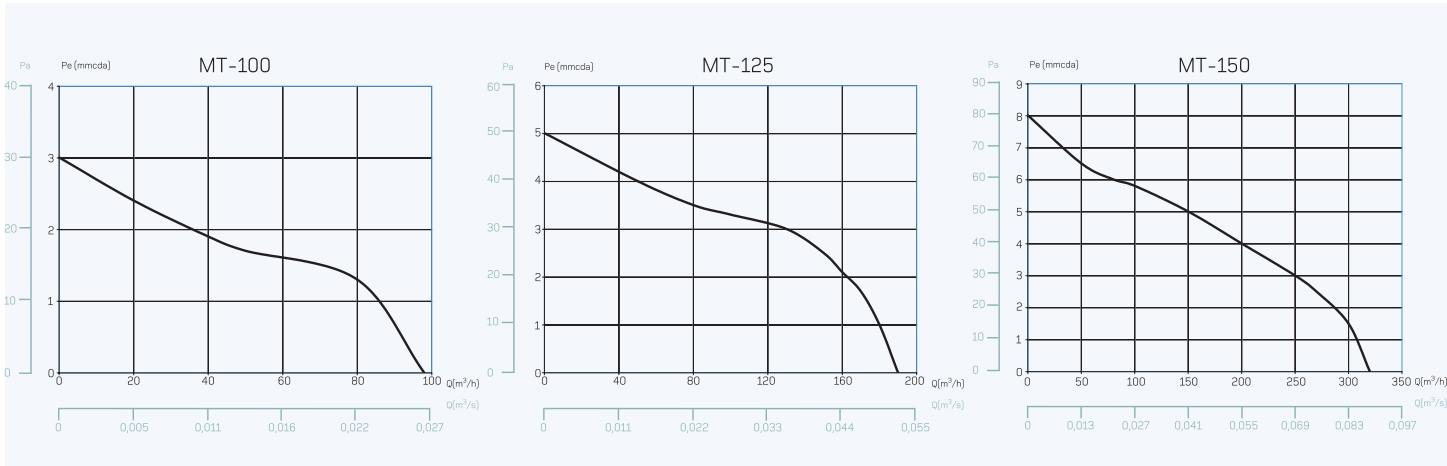

# COMPREHENSIVE VENTILATION SOLUTIONS

## WHAT WE OFFER

Integral ventilation solutions. Reliability, Quality, Innovation and Design. Proven experience in ventilation. International industrial capacity. Global service. And most importantly to our customers: **BENEFITS AND ADVANTAGES**

## COMPREHENSIVE VENTILATION SOLUTIONS:

**CATA** provides subscribers, wholesalers and professionals from the sector an extensive product range, which will allow them to choose the most suitable model for every ventilation case or need, at both domestic and industrial level, and now also **models and ranges to comply with the Technical Building Code (CTE), in accordance with Royal Decree 314/2006, dated 17th March 2006.**

## RELIABILITY, QUALITY, INNOVATION AND DESIGN

These concepts are basic and mandatory for **CATA** and are the main basis for all our products. For this reason, a qualified team of engineers assisted by the most modern design systems work to ensure the highest levels of quality and innovation to offer highly reliable ventilation products manufactured according to the **ISO 9001/2000 standard Management System.**

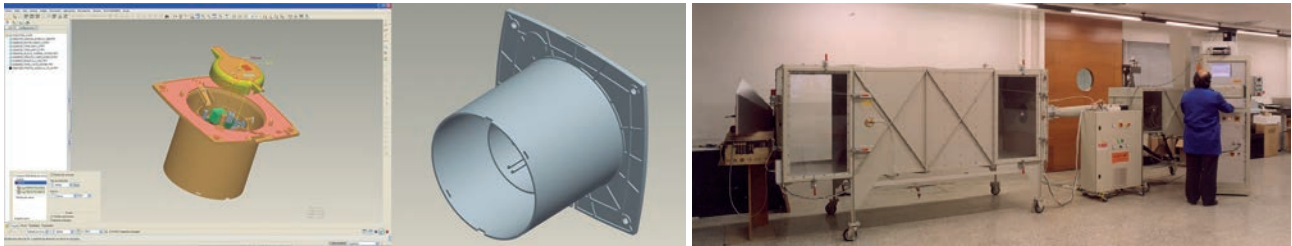

## PROVEN EXPERIENCE IN VENTILATION

A pioneer in the manufacturing of fans, **CATA** has over 60 years' experience in ventilation, strengthening its position as a world leader thanks to the export of proprietary technology and differentiated products.

## INTERNATIONAL INDUSTRIAL CAPACITY

**CATA** has a very important industrial asset, with several production centres around the world equipped with the most modern technology and machinery to be able to offer efficient and competitive distribution of our products and components.

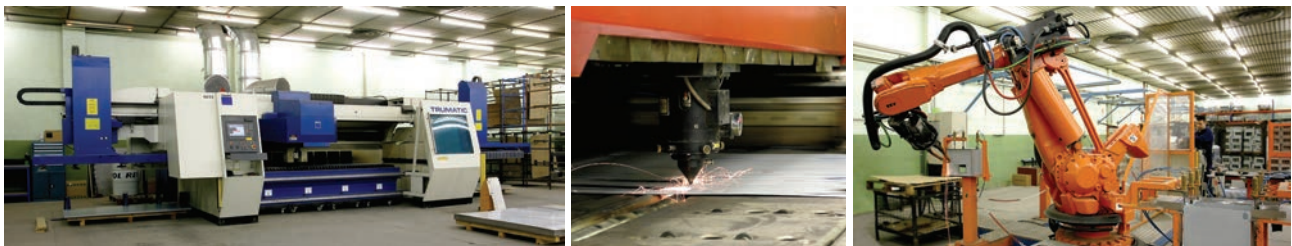

## GLOBAL SERVICE

**CATA** has a multicultural team with a high level of training and a clear customer care and service orientation. In addition, to offer a better service, we have logistics and distribution centres and subsidiaries around the world.

## AND MOST IMPORTANTLY TO OUR CUSTOMERS: BENEFITS AND ADVANTAGES

These are the main aims that the **CATA Ventilation Division** wishes to offer the distributors, customers and professionals in the sector. For this reason, we work and renew our efforts daily to ensure that these objectives are possible.

# Concepts

## BASIC VENTILATION CONCEPTS

### WHAT IS VENTILATION?

Ventilation is understood to be the replacement of a portion of air which is considered undesirable (polluted), by another that provides an improvement both in terms of purity, and of temperature, humidity, etc.

### FUNCTIONS

To maintain the air in an enclosure under suitable conditions of temperature, humidity, pressure, speed and degree of pollution to ensure the health and wellbeing of people, or living beings.

### FLOW RATE

This is the amount of air displaced in a given unit of time. (The flow given in the technical specifications is at free discharge, in other words, with no pressure loss). Flow is shown as Q and is usually expressed in m<sup>3</sup>/h, although it is also commonly expressed in m<sup>3</sup>/min, m<sup>3</sup>/sec, l/s, C.F.M

$$1\text{m}^3/\text{h} = 3,6 \text{ l/s}$$

$$1,7 \text{ m}^3/\text{h} = 1 \text{ C.F.M}$$

The **FLOW RATE** and the section are related as follows:

$$Q = V * S = \text{m}^3/\text{h}$$

$$V = \text{Air speed (m/sec)}$$

$$S = \text{Section (m}^2\text{) of the duct}$$

$$S = \frac{d^2 * \Pi}{4}$$

### WHAT IS PRESSURE?

It is the pushing force per surface unit that air needs to circulate and overcome the resistance of the system (pressure losses).

Pressure is given in: mmH<sub>2</sub>O and Pa

$$9,8 \text{ Pa} = 1 \text{ mmH}_2\text{O}$$

### THERE ARE THREE TYPES OF PRESSURE:

**Static Pressure (Pe):** This is the force of the air in all directions on the walls of the tube, in a perpendicular direction to them.

**Dynamic Pressure (Pd):** Is the force that accelerates the air from zero to the velocity of the system. It is manifested only in the direction of the air.

There is a formula that links dynamic pressure and speed:

$$Pd = (V / 4,04)^2$$

### Speed Table with its Dynamic Pressure (table 3)

Speed (m/s)	Dynamic Pressure mmH <sub>2</sub> O
1	0.06
2	0.24
3	0.55
4	0.98
5	1.53
6	2.20
7	3.00
8	3.92
9	4.96
10	6.12
11	7.41
12	8.82
13	10.35
14	12.00
15	13.78
16	15.68
17	17.70
18	19.85
19	22.11
20	24.50
21	27.01
22	29.65

**Total Pressure:** This is the sum between the static pressure and the dynamic pressure  $P_t = P_e + P_d$

### WHAT IS NOISE?

It is the audible sound, that is propagated through the air and which is unpleasant to the receiver.

The **Sound Pressure (Lp)** level is what we really hear and it varies according to the premises and the distance between the source of the noise (extractor or fan) and the receiver.

The **Sound Power (Lw)** level is the amount of sound energy of a sound source (extractor or fan) every second and it is constant, in other words, it does not vary according to the premises or the distance from the sound source.

# Concepts

## BASIC VENTILATION CONCEPTS

Noise	dB	Examples
		Thunder
DEAFENING	120	Cannon fire
	110	Steam whistle
VERY STRONG	100	Train in a tunnel
	90	Street with dense traffic
	80	Noisy factory
STRONG		Noisy office
	70	Medium-sized workshop
	60	Radio with the volume up high
MODERATE	60	Large shop
	50	Office
GENTLE		Public library
	40	Country road
	30	Scrunching up paper Quiet conversation
VERY GENTLE	20	Peaceful church
	10	Silent night
	0	Hearing limit

### HOW TO CHOOSE A FAN

You need to know the following parameters:

- Output
- Pressure
- Sound level
- Type of Electricity Supply

**Output** ( $Q$  m<sup>3</sup>/h): You have to determine the necessary flow according to:

1. The recommended renewals with regard to the volume of the premises in m<sup>3</sup> and the activity there.

$$Q = m^3 * \text{Renow/h}$$

### RENEW./HOURLY TABLE

Result of Health and Safety studies/Experience

#### INDUSTRIAL PREMISES

Noxious atmospheres	30-60
Goods deposit	3-6
Cast-iron	20-30
Industrial laundry	15-30
Machine room	20-30
Workshop (general)	8-10
Workshop with kilns	30-60
Tooling workshop	5-10
Paint workshop	30-60
Welding workshop	15-30
Dry cleaner	20-30

#### SERVICES SECTOR AND PREMISES

	NR/h
Classroom	2-4
Bank	3-4
Bar-café	10-12
Library	3-5
Cinema-theatre	10-15
Industrial kitchen	15-30
Canteen	5-10
Recording studio	10-12
Garage	6-8
Gym	6-12
Entrance hall	3-5
Hospitals	4-6
Public lavatories	8-15
Laundry	15-30
Offices	4-8
Baker's	20-30
Restaurant	5-10
Dance hall	6-8
Conference room	8-12
Hairdressing salon	10-15
Meeting room	4-8

2. The recommended renewals with regard to the number of people that there are in the premises.

$$Q = n^{\circ} \text{ person} * m^3/h$$

Normal activity with no smoking	29 m <sup>3</sup> /h per person
Normal activity with smoking	58 m <sup>3</sup> /h per person
Light physical activity	45 m <sup>3</sup> /h per person
Industrial warehouses and premises	60 m <sup>3</sup> /h per person

# Concepts

## BASIC VENTILATION CONCEPTS

3 ■ When localised extraction is required in the place where the contaminating source is, the flow (**Q**) will be determined taking the following into account:

- Surface area of the hood
- Speed of catchment
- Speed of transport by the recommended renewals system with regard to the number of people that there are in the premises.

$$Q = 3.600 \cdot V \cdot S = \text{m}^3/\text{h}$$

**Q** = Necessary air flow (**m<sup>3</sup>/h**)

**V** = Speed of catchment (**m/h**)

**S** = Hood or ducting section (**m<sup>2</sup>**)

LOCALISED EXTRACTION GUIDE COOKER HOODS			
Hood Class	Speed Catchment in m/sec On hood surface	Calculation per m2 of surface area of the hood	Speed of transport m/sec
4 sides open	from 1 to 1,2 m/sec.	3.500 to 4.500 m <sup>3</sup> /h	from 6 to 10 m/sec.
3 sides open	from 0,85 to 1 m/sec.	3.000 to 3.500 m <sup>3</sup> /h	
2 sides open	from 0,75 to 0,85 m/sec.	2.700 to 3.000 m <sup>3</sup> /h	
1 side open	from 0,5 to 0,75 m/sec.	1.750 to 2.700 m <sup>3</sup> /h	

**cata** 





cata 

**CNA**  
●●●group

**CATA ELECTRODOMÉSTICOS, S.L.** - c/ del Ter, 2 - 08570 TORELLÓ (Barcelona) SPAIN  
Dpto. Com. +34 93 859 41 53 - Dpto. Export. +34 93 859 41 58  
Tels. +34 859 41 00 - Fax +34 93 859 41 01 - [www.cnagroup.es](http://www.cnagroup.es) - [cna@cnagroup.es](mailto:cna@cnagroup.es)

ISO 9001  
BUREAU VERITAS  
Certification



N° ES944225-1